

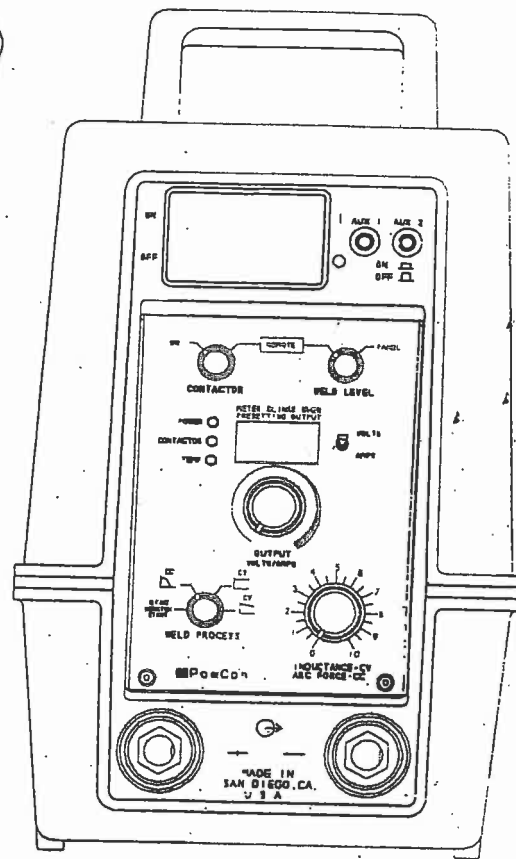

! IMPORTANT !
-FOR YOUR SAFETY-
READ THIS MANUAL BEFORE
INSTALLING OR USING EQUIPMENT

OPERATION MANUAL

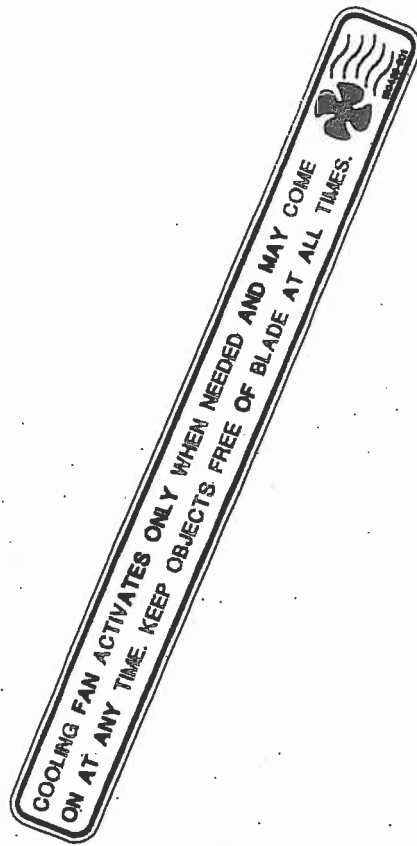

400SMT 230/460V Fan On Demand

TABLE OF CONTENTS

SAFETY

Definitions	1
Safety Information	1
Electric Shock	1
Personal Protection	2
Fire Safety	2
Ventilation	3
Safety References	3

GENERAL INFORMATION

Description of Equipment	4
Specifications	4
Theory of Operation	5

INSTALLATION

Unpacking New Equipment	6
U.L. Requirements	6
Equipment Installation	6
Fuse Size	6
Primary Wire Size	7
Single Phase Installation	7
Three Phase Installation	7
Engine Driven Generator Use	7
Location of Equipment	7
Output Connections	8
Welding Cable	8
Remote Contactor Control/Wirefeed Power Connections	8
Wirefeeder Control Cable	9
Procedure for Input Voltage Change-Over	10
Location 1: Working Capacitor Board Change-Over	10
Location 2: Main Transformer Change-Over	10
Bleeder Resistor Assembly	12
Construction	12
Use	12

OPERATION

Function of Operating Controls and Connections	14
Circuit Breaker	14
5 Amp Circuit Breaker (AUX 1)	14
10 Amp Breaker (AUX 2)	14
Contactor Control Switch	14
Weld Level (volts/amps) Select Switch	14
Power ON Indicator	14
Contactor ON Indicator	14
Temperature Indicator	14
Digital Volts/Amps Meter	14
Volts/Amps Selector Switch	14
Output (volts/amps) Potentiometer	15

Weld Process Selector Switch	15
(CV) Inductance/(CC) Arc Force Control	15
Output Terminals	15
Remote Connector	17
Hot Start Control Potentiometer	17
Duty Cycle	18
Optimum CAG Performance	18

MAINTENANCE

Service	19
Internal Cleaning	19
External Troubleshooting	19
General Troubleshooting	19
Internal Troubleshooting	19

DRAWINGS AND PARTS LISTS

Side View Parts List	20
Side View	21
Top View Parts List	22
Top View	23
Bottom View Parts List	24
Bottom View	25
Front Panel Parts List	26
Front Panel	27
Rear Panel Parts List	28
Rear Panel	28
Front View Parts List	29
Front View	30

LIST OF TABLES

Specifications of PowCon 400SMT	4
Recommended Fuse Sizes Based on National Electrical Code Requirements	6
Recommended Primary Cable Size Based on National Electrical Code Requirements	7
Recommended Copper Welding Cable Sizes Based on 60% Duty Cycle and Combined Length of Electrode Ground Cable	8

LIST OF FIGURES

Electronic Block Diagram of Converter Principle	5
Wirefeeder Control Cable with Schematic	9
230/460 VAC Voltage Change-Over Configuration	11
Bleeder Resistor Use	13
Front Panel	16
Rear Panel	17
Weld Process Guide	18
Side View	21
Top View	23
Bottom View	25
Front Panel	27
Rear Panel	28
Front View	30

SCHEMATIC

Fan On Demand	32 & 33
Non Fan On Demand	34 & 35

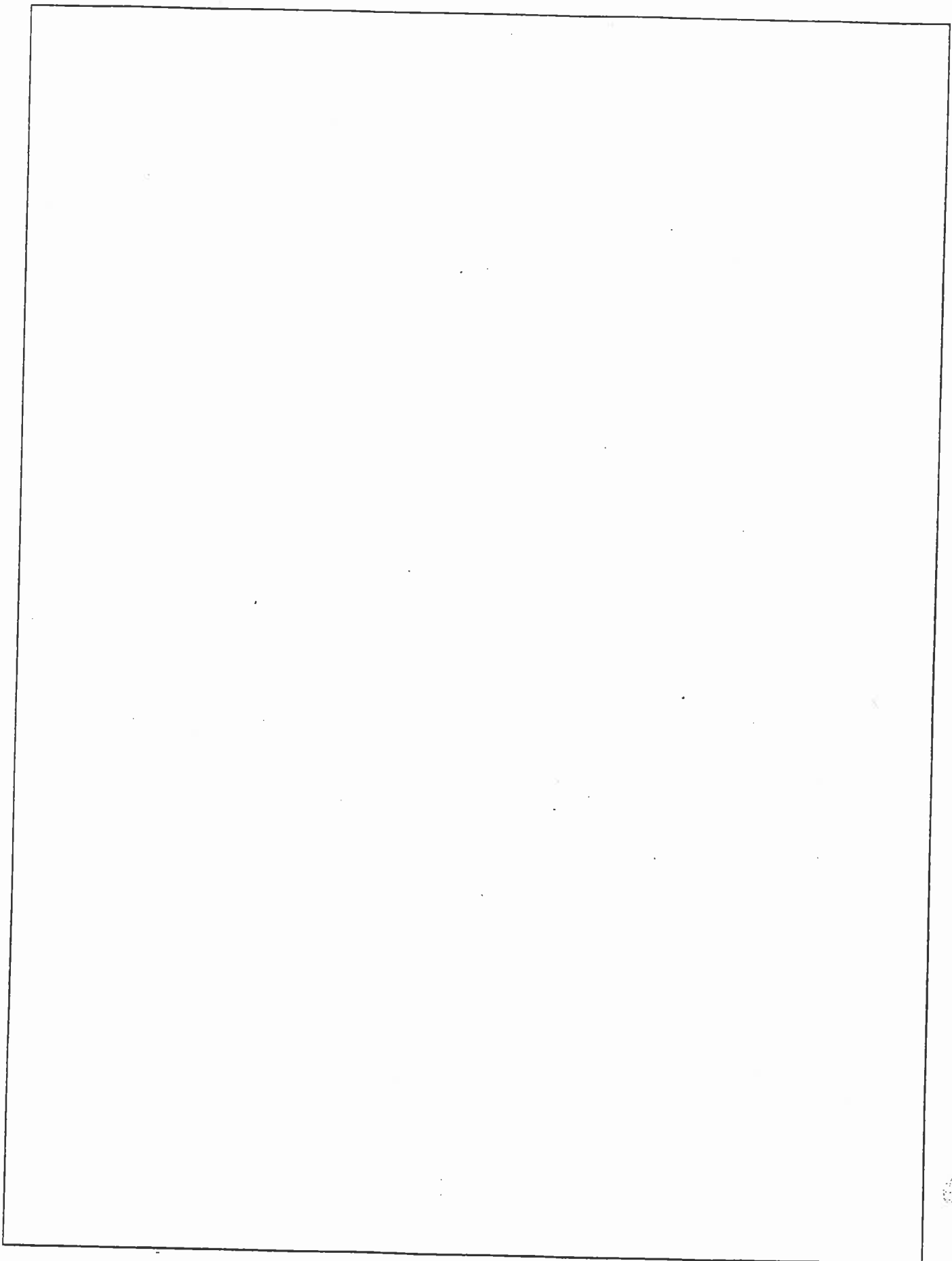

SAFETY

! IMPORTANT !

THIS MANUAL HAS BEEN DESIGNED FOR EXPERIENCED WELDING AND CUTTING EQUIPMENT OPERATORS AND MUST BE READ COMPLETELY BEFORE USING THIS EQUIPMENT. IF YOU LACK EXPERIENCE OR ARE UNFAMILIAR WITH THE PRACTICES AND SAFE OPERATION OF WELDING AND CUTTING EQUIPMENT, PLEASE CONSULT YOUR FOREMAN. DO NOT ATTEMPT TO INSTALL, OPERATE, OR PERFORM MAINTENANCE ON THIS EQUIPMENT UNLESS YOU ARE QUALIFIED AND HAVE READ AND UNDERSTOOD THIS MANUAL. IF IN DOUBT ABOUT INSTALLING OR OPERATING THIS EQUIPMENT, CONTACT YOUR DISTRIBUTOR OR THE CUSTOMER SERVICE DEPARTMENT OF PowCon.

DEFINITIONS

Throughout this manual, NOTE, CAUTION, WARNING and DANGER are inserted to call attention to particular information. The methods used to identify these highlights and the purpose for which each is used, are as follows:

NOTE

Operational, procedural, and background information which aids the operator in the use of the machine, helps the service personnel in the performance of maintenance, and prevents damage to the equipment.

CAUTION

An operational procedure which, if not followed, may cause minor injury to the operator, service personnel and/or bystanders.

WARNING

An operational procedure which, if not followed, may cause severe injury to the operator, service personnel, or others in the operating area.

DANGER



An operational procedure which, if not followed, will cause severe injury or even death to the operator, service personnel or bystanders.

SAFETY INFORMATION

Safety is a combination of good judgement and proper training. Operation and maintenance of any arc welding and cutting equipment involves potential hazards. Individuals who are unfamiliar with cutting and welding equipment, use faulty judgement or lack proper training, may cause injury to themselves and others. Personnel should be alerted to the following potential hazards and the safeguards necessary to avoid possible injury. In addition, before operating this equipment, you should be aware of your employer's safety regulations.

BE SURE TO READ AND FOLLOW ALL AVAILABLE SAFETY REGULATIONS BEFORE USING THIS EQUIPMENT.

ELECTRIC SHOCK



THE VOLTAGES PRESENT IN THE WELDING AND CUTTING ENVIRONMENT CAN CAUSE SEVERE BURNS TO THE BODY OR FATAL SHOCK. THE SEVERITY OF ELECTRICAL SHOCK IS DETERMINED BY THE PATH AND THE AMOUNT OF CURRENT THROUGH THE BODY.

A) Install and continue to maintain equipment according to USA Standard C1, National Electric Code.

B) Never allow live metal parts to touch bare skin or any wet clothing. Use only dry gloves.

C) When welding or cutting in a damp area, or when standing on metal, make sure you are well insulated by wearing dry gloves, rubber soled shoes, and by standing on a dry board or platform.

D) Do not use worn or damaged welding or torch cables. Do not overload the cables. Use well maintained equipment.

E) When not welding/cutting, turn equipment OFF. Accidental grounding can cause overheating and create a fire hazard. Do not coil or loop the cable around parts of the body.

SAFETY

F) The ground cable should be connected to the workpiece as close to the work area as possible. Grounds connected to building framework or other locations remote to the work area reduce efficiency and increase the potential hazard of electric shock. Avoid the possibility of the cutting current passing through lifting chains, crane cables or other electrical paths.

G) Keep everything dry you might touch, including clothing, the work area, welding gun, torch and welding or cutting machines. Fix water leaks immediately. Do not operate equipment standing in water.

H) Never use a cutting torch or welding gun which is damaged or contains cracks in its housing.

I) Refer to AWS-Z49.1 for grounding recommendations.

PERSONAL PROTECTION



SKIN AND EYE BURNS RESULTING FROM BODY EXPOSURE TO ELECTRIC-ARC WELDING AND CUTTING RAYS OR HOT METAL CAN BE MORE SEVERE THAN SUNBURN.

A) Use a proper face shield fitted with the correct filter (#10 or greater) and cover plates to protect your eyes, face, neck and ears from the sparks and rays of the cutting/welding arc when cutting/welding or observing cutting/welding. Warn bystanders not to watch the arc and not to expose themselves to the cutting/welding arc rays or to hot metal.

B) Wear flameproof gauntlet-type gloves, a heavy long-sleeve shirt, cuffless trousers, high-topped shoes, and a welding helmet or cap (for hair protection) to protect the skin from arc rays and hot sparks or hot metal.

C) Protect other nearby personnel from arc rays and hot sparks with a suitable non-flammable partition.

D) Always wear safety glasses or goggles when in a cutting or welding area. Use safety glasses with side shields or goggles when chipping slag or grinding. Chipped slag is hot and may travel a considerable distance. Bystanders should also wear safety glasses or goggles.

E) Compressed gas cylinders are potentially dangerous, refer to the suppliers for proper handling procedures.

F) Wear ear plugs or other ear protection devices when operating cutting or welding equipment.

FIRE SAFETY



HOT SLAG OR SPARKS CAN CAUSE A SERIOUS FIRE WHEN IN CONTACT WITH COMBUSTIBLE SOLIDS, LIQUIDS OR GASES.

A) Move all combustible materials well away from the cutting area or completely cover materials with a non-flammable covering. Combustible materials include but are not limited to wood, clothing, sawdust, gasoline, kerosene, paints, solvents, natural gases, acetylene, propane, and similar articles.

B) Do not weld, cut or perform other hot work on used barrels, drums, tanks or other containers until they have been completely cleaned. There must be no substances in the container which might produce flammable or toxic vapors.

C) For fire protection, have suitable extinguishing equipment handy for instant use.

SAFETY

VENTILATION



WELDING AND CUTTING FUMES AND GASES, PARTICULARLY IN CONFINED SPACES, CAN CAUSE DISCOMFORT AND PHYSICAL HARM IF INHALED OVER AN EXTENDED PERIOD OF TIME.

- A) At all times, provide adequate ventilation in the welding and cutting area by either natural or mechanical means. Do not weld or cut on galvanized, zinc, lead, beryllium or cadmium materials unless positive mechanical ventilation is provided to prevent inhaling fumes and gases from these materials.
- B) Do not weld or cut in locations close to chlorinated hydrocarbon vapors coming from degreasing or spraying operations. The heat of arc rays can react with solvent vapors to form phosgene, a highly toxic gas, and other irritant gases.
- C) If you develop momentary eye, nose or throat irritation during welding or cutting, it is an indication that the ventilation is not adequate. Stop work and take the necessary steps to improve ventilation in the welding or cutting area. Do not continue to weld or cut if physical discomfort persists.
- D) Use an air supplied respirator if ventilation is not adequate to remove all fumes and gases.
- E) Beware of gas leaks. Welding or cutting gases containing argon are more dense than air and will replace air when used in confined spaces. Do not locate gas cylinders in confined spaces. When not in use, shut OFF the gas supply at its source.
- F) Refer to AWS Standard Z49.1 for specific ventilation recommendations.

SAFETY REFERENCES

The following publications provide additional information on important welding safeguards.

- A) ANSI/ASC Z49.1-1988, American National Standard "Safety in Welding and Cutting".
- B) Bulletin No. F4-1, "Recommended Safe Practices for the Preparation for Welding and Cutting Containers and Piping that have held Hazardous Substances".
- C) OSHA Safety and Health Standards, 29CFR 1910, available from the United States Department of Labor, Washington, DC 20210.
- D) NFPA Standard 51B, "Fire Prevention in Use of Cutting and Welding Processes", available from the National Fire Protection Association, 470 Atlantic Avenue, Boston, MA 00210.
- E) NEMA Standards Publication/No. EW1-1989, Electric Arc-Welding Apparatus, approved as ANSI C87.1-1989. Available from National Electrical Manufacturers Association, 155 E. 44th Street, New York, NY 10017.

GENERAL INFORMATION

DESCRIPTION OF EQUIPMENT

PowCon 400SMT is a multi process CC/CV power source that performs MIG (GMAW), Stick (SMAW), Scratch Lift - Arc Start Tig (GTAW), pulsed Mig welding and carbon arc gouging (CAG).

SPECIFICATIONS

(Subject to change without notice)

PowCon 400SMT welding power source:

- A) Power Input and Output (see Table 1)
- B) Open Circuit Voltage - 80V maximum
- C) Welding Current Range - adjustable from 10 to 400 amps

- D) Weight 85 pounds (38.6 Kg)
- E) Dimensions Height 17" (43 cm)
..... Width 10" (26 cm)
..... Depth 19" (49 cm)

Accessories:

- A) Remote control cable extension - 25 feet (7.6M) or 50 feet (15.2M) lengths
- B) Output cable connectors (DINSE or TWECO)
- C) Relay Kit #250082-001 for wirefeeder which returns 115VAC contact closure signal.

TABLE 1

SPECIFICATIONS OF PowCon 400SMT

Primary Input	Rated Welding Current/Amps	Welding Amp Range	Open Circuit Voltage	Amps Input At Rated Load Output			KVA	KW	EFF	Dimensions	Weight	
				230V/460V	380V	575V					Net	Ship
Three Phase	100% Duty Cycle 250 amps @ 30V	10-400	80 max	26.2	13.1	15.9	10.5	9	82.5%	Height: 17" (43 cm) Width: 10" (26 cm) Depth: 19" (49 cm)	85 lbs. (38.6 Kg)	91 lbs. (41.4 Kg)
	60% Duty Cycle 300 amps @ 32V			33.4	16.7	20.3	13.4	13.3	11.6			
Single Phase	100% Duty Cycle 160 amps @ 26.4V	10-300	80 max	26	N/A	N/A	N/A	N/A	N/A			
	60% Duty Cycle 200 amps @ 28V			41	N/A	N/A	N/A	N/A	N/A			

* Three input voltage models available - 230/460V, 380V, 575V

GENERAL INFORMATION

THEORY OF OPERATION

The PowCon Welding Power Source uses the frequency converter principle to produce direct current DC power. In contrast to the conventional transformer rectifier, the frequency converter design offers two main advantages: (1) lower weight and size, and (2) increased electrical efficiency.

For the PowCon, the input alternating current (AC) primary power is passed through a circuit breaker to a 6 pulse full wave bridge rectifier, where the input is transformed to DC power. The DC current output of the rectifier is fed to an inverter of series capacitor switching type. Using SCR's (thyristors), the DC current is switched alternately ON and OFF. The action of charging and discharging the working capacitor's creates a new alternating current (AC). The frequency of the firing of the SCR's is dependent upon the output demand, i.e., the greater the output power required, the higher the frequency.

The new alternating current, with its higher frequency provided by the switching devices (SCR's), is fed into the main

transformer. One advantage of higher frequency alternating current is that the size of the transformer can be significantly reduced. The PowCon main transformer weighs 12 pounds, versus approximately 200 pounds used in the conventional transformer rectifier. The transformer takes the higher voltage of the switching SCR's and transforms it to the welding voltage range.

The final step in the production of weld current is the AC output of the transformer which is rectified by diodes into direct current (DC) for welding. The whole sequence of operations from the primary (AC) input to the weld output (DC), is regulated by the PC board through control logic feedback.

Additionally, input AC power is fed to a transformer that generates auxiliary power. Aux 1 and Aux 2 is AC power routed to a remote connector and are used for accessories such as Wire Feeders, Remote Arc Starters, Pulsers, etc... Furthermore, the board provides the power to operate the Control and Logic board and provides power to the fan motor. The Fan Motor circulates cooling air inside the power source only on power-up and when welding. The fan ON time directly depends on welding time and settings.

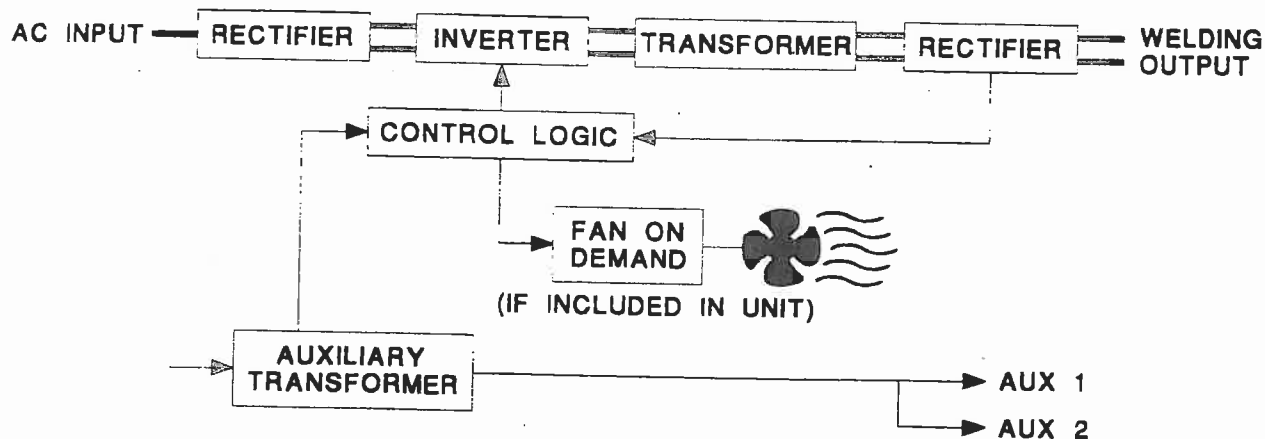

Figure 1, Electronic Block Diagram of Converter Principle

INSTALLATION

UNPACKING NEW EQUIPMENT

(Receiving and Handling)

Remove the **PowCon** Welding Power Source from its shipping carton and inspect for any possible damage that might have occurred during shipping. Make sure that all items on the packing list are accounted for and identified. One copy of the **PowCon** Operation Manual is packed with each **PowCon** unit.

Any claims for loss or damage that may have occurred in transit must be filed by the PURCHASER with the CARRIER. Copies of the bill of lading and freight bill will be furnished by the carrier on request, if the need to file a claim arises. When requesting information concerning this equipment, it is essential that model description, serial number and/or part number of the equipment be supplied.

NOTE

TO ASSURE A VALID WARRANTY, YOU MUST COMPLETE AND RETURN THE WARRANTY CARD (ENCLOSED WITH ALL PRODUCTS) WITHIN 10 DAYS OF THE PURCHASE DATE.

U.L. REQUIREMENTS

READ BEFORE CONNECTING POWER

Only a qualified electrician should perform the installation of the **PowCon** unit to primary power. All installations of this type must conform to the regulations of the National Electrical Code and any other local codes which may be applicable.

These regulations include, but are not limited to, using the proper ampacity primary cord, properly phasing the connection to three phase power with respect to the ground line (green), and providing the proper strain relief between the primary cable and the field connection box or wiring box.

When an attachment plug is installed, it must be U.L. Listed, complying with paragraph 9.10 of U.L. 551, Transformer-Type Arc Welding Machines. Make sure the chosen pin configuration is appropriate for the primary voltage you are using. A typical plug with the appropriate NEMA pin configuration would be (1) Hubbell Cat# 9451/NEMA 14.50P for 208V/1Ø and 230V/3Ø, and (2) Hubbell Cat# 2431/NEMA L16.20P for 460V/3Ø.

The green lead on the primary cable is the ground lead. This must be connected to the indicated terminal on the plug. The remaining three phases may be connected in any order to the other terminals on the plug. In the case of a screw connection, care should be taken to ensure that the stranded leads on the primary cable are properly seated before tightening. There should be no loose strands protruding from the sides or back of the terminal after tightening.

After connecting the leads, attach the plug casing and the strain relief. The strain relief should grip at least 1/2" of the primary cable's outer jacket. Under no circumstances should the strain relief be connected only to the individual leads of the primary cable. This will result in a shortened cable life and unsatisfactory strain relief.

Before connecting the unit to the primary power, check to see that the unit is wired for the proper voltage. Refer to Page 10 of this manual for the proper voltage change-over procedure.

EQUIPMENT INSTALLATION

(Input Power Requirements)

The **PowCon** 400SMT is manufactured for use on 230 or 460 volt, 50 or 60 hertz, three phase power and 230/208 volts single phase power.

The **PowCon** 400SMT comes from the factory wired for 440 to 480 VAC input. To perform a voltage change-over, be sure to review and understand the voltage change-over procedure found on Page 10.

It is not necessary to check the phasing of the power lines. The **PowCon** 400SMT will work properly on any phase sequence for three phase input voltage.



DANGER

AN ELECTRICAL GROUND MUST ALWAYS BE PROVIDED TO CONNECT TO THE GREEN WIRE ON THE FACTORY INSTALLED PRIMARY CABLE.

FUSE SIZE

The **PowCon** 400SMT is equipped with a 14 foot (4.3 M) power cord attached. The power cord size is 10 AWG for 230 volt and 460 volt operation. For proper fuse size see Table 2.

TABLE 2

RECOMMENDED FUSE SIZES BASED ON NATIONAL ELECTRICAL CODE REQUIREMENTS

Input Voltage	Maximum Amperage	Recommended Fuse Capacity	Recommended Plug Capacity
230V, 3Ø	46A	50A	40A
460V, 3Ø	23A	30A	25A
208V, 230V, 1Ø	41A	45A	35A

*Maximum current demand is based on an output of 35.2 VDC and 375A for 3 phase input. For single phase input maximum current demand is based on output of 28 VDC and 200A.

INSTALLATION

PRIMARY WIRE SIZE

Additional lengths of primary cable are to be considered extension cords to the factory supplied power cord. To maintain the necessary degree of safety, the use of suitably rated U.L. recognized male/female connector plugs is required. Extension primary cord lengths must be of the same grade wire for their entire length. See Table 3.

TABLE 3

RECOMMENDED PRIMARY CABLE SIZE BASED ON NATIONAL ELECTRICAL CODE REQUIREMENTS

Extension Cable Length	Required Primary Cable Size
250 Feet or Less (176M)	10 AWG
250 Feet to 400 Feet (122M)	8 AWG
400 Feet to 650 Feet (198M)	6 AWG

*The entire extension cable length must be made of the required cable size. For example, a 500 foot extension would be made of 6 AWG cable with appropriate U.L. recognized plugs to connect to the factory provided 14 foot primary.



DANGER

NEVER CONNECT OR DISCONNECT THE PRIMARY UNLESS THE UNIT IS TURNED OFF AT THE CIRCUIT BREAKER LOCATED ON THE FRONT PANEL. THE PRIMARY SUPPLY LINE SHOULD ALWAYS BE SWITCHED OFF DURING INSTALLATION.

A GROUND MUST ALWAYS BE PROVIDED TO CONNECT TO THE GREEN WIRE ON THE FACTORY INSTALLED PRIMARY.

SINGLE PHASE INSTALLATION

Perform the following steps on the factory equipped primary cable:

- Check if unit is internally wired for required primary voltage. The current voltage setting is indicated on the data label on the top of the unit.
- Connect green wire to ground.
- Connect both white and black wires to "HOT" legs.
- Electrically isolate red wire.

NOTE

DO NOT CONNECT THE RED OR GREEN WIRE TO A NEUTRAL.

THREE PHASE INSTALLATION

Perform the following steps on the factory equipped primary cable:

- Check if unit is internally wired for required primary voltage. The current voltage setting is indicated on the data label on the top of the unit.
- Connect green wire to ground.
- Connect white, black and red wires to "HOT" legs.

ENGINE DRIVEN GENERATOR USE

Failure to take special precautions with the PowCon Welding Power Source and engine driven generators will result in damage to equipment. The following special startup procedure MUST be followed to prevent damage to both the unit and the generator. Generator output voltage must be regulated to within $\pm 10\%$ of 230/460 volts depending on input voltage wiring of the welding power source.

CAUTION

NEVER START UP THE GENERATOR WITH THE CIRCUIT BREAKER ON THE PowCon UNIT IN THE UP/ON POSITION. THE PowCon UNIT MAY BE SWITCHED ON AT THE CIRCUIT BREAKER ONLY AFTER THE GENERATOR IS STARTED AND RUNNING STEADY (AT LEAST TEN SECONDS).

Perform the following steps on the factory equipped primary cable:

- Check if unit is internally wired for required primary voltage.
- Connect green wire to ground.
- Connect either single phase or three phase installation as required.

LOCATION OF EQUIPMENT

NEMA Standard EW1-2.02 approved as ANSI C87.1-1976 outlines both usual and unusual service conditions for a welding power source. The PowCon series of welding power sources have been designed and manufactured to meet the usual service conditions as well as conform to the other NEMA standards. If an unusual service condition is required, PowCon should be consulted.

The small size and unique design of the PowCon series of welding power sources requires the operator be aware of certain safeguards regarding the proper procedure for movement and placement of the unit. Good judgement and compliance with your particular job site safety requirements are essential. The following safeguards are recommended.

Install the equipment in accordance with OSHA and National Electrical Code Standards, or other applicable standards.

INSTALLATION

COOLING

NOTE

400SMT UNITS, EQUIPPED WITH "FAN ON DEMAND" THE FAN WILL COME ON AT POWER-UP AND WHEN WELDING.

Locate the PowCon Welding Power Source so that air flow into and out of the back panel is not obstructed. Avoid placing the unit where dust or grinding particles will be directed into the unit.

ACCESS

Locate the PowCon Welding Power Source where there is room for the operator to manipulate controls or change the connections on either the front or back panel. Avoid placing the unit in a hallway or other area where foot traffic might be impeded.

SECURITY

Locate the unit where it can be secured to a platform, deck or other structure which is capable of safely supporting the unit and any other potential load.

LIFTING

Always lift the unit using the handles provided. When lifting and carrying the unit, it is recommended that two people be used. The unit is designed to be lifted using a suitably rated and inspected choker (made of rope or nylon) run through both handles. Refer to the applicable OSHA standards or contact PowCon for any questions regarding the lifting of this unit. Do not lift a power source/wirefeeder combination when the wirefeeder is mounted to the power source handles. Always disassemble the wirefeeder from the power source before lifting.



DANGER

WARNING

DO NOT ALLOW THE UNIT TO REMAIN OPERATING WHEN LIFTING OR MOVING IT.

DO NOT DRAG OR LIFT THE UNIT BY THE PRIMARY OR SECONDARY CABLES. EXERCISE CARE IN THE HANDLING OF PRIMARY AND SECONDARY CABLES TO AVOID WEAR AND LOSS OF ELECTRICAL INSULATION.

DO NOT LIFT THE UNIT UNLESS ALL 10 FLANGE SCREWS AND NUTS HOLDING THE TOP AND BOTTOM CASES ARE TIGHT.

ANY TIME PowCon EQUIPMENT IS PLACED ABOVE GROUND LEVEL, THE POTENTIAL HAZARD OF THE UNIT FALLING EXISTS.

OUTPUT CONNECTIONS

WELDING CABLE

Run electrode and ground cables of the appropriate size as shown in Table 4. To avoid excessive heat losses during welding, all output connections, lugs and cables should be secure and well insulated. Failure to use proper cable sizes contributes to lost efficiency of the power source and excessive consumption of electrical power.

The electrode and work leads have to be assembled using customer supplied welding cable and cable connectors. After the cables are assembled, connect the electrode lead to the negative (-) jack and the work lead to the positive (+) jack for straight polarity operation. For reverse polarity operation, the electrode lead is connected to the positive (+) jack and the work lead is connected to the negative (-) jack.

NOTE

LOCATE THE PowCon UNIT SO THAT THE AIR FLOW INTO AND OUT OF THE BACK OF THE UNIT IS NOT OBSTRUCTED.

TABLE 4

RECOMMENDED COPPER WELDING CABLE SIZES BASED ON 60% DUTY CYCLE AND COMBINED LENGTH OF ELECTRODE GROUND CABLE*

0' to 150' (45.7M)	150' to 200' (61M)	200' to 250' (76M)
1/0	2/0	3/0

*Use of aluminum cable requires increase by two AWG sizes over recommended copper cable size. Recommended cable sizes for other duty cycles and output currents can be found in Volume 2, WELDING HANDBOOK, 7th Edition, published by the American Welding Society.

REMOTE CONTACTOR CONTROL/WIREFEED POWER CONNECTIONS

The remote control devices come with a 17-pin connector plug which connects to the remote terminal on the panel of the PowCon unit.

INSTALLATION

To connect the remote control device, insert the 17-pin plug from the control cable of the device fully into the receptacle on the panel. Ensure that the plug keyways align with the receptacle keys. Rotate the plugs threaded collar clockwise as far as possible onto the receptacle threaded body to secure the plug in the receptacle.

WIREFEEDER CONTROL CABLE

The control cable for the wirefeeder and PowCon 400SMT interface comes with a 17 pin connector designed to mate with the remote receptacle on the panel. The wiring schematic for the control cable is shown in Figure 2.

NOTE

UNLESS OTHERWISE SPECIFIED, THE PowCon 400SMT'S SHIPPED FROM THE FACTORY WITH ON/OFF CONTROL RESPONSIVE TO CONTACT CLOSURE ONLY.

The wirefeeder control cable can be adapted for use with the PowCon 400SMT and any other manufacturer's wirefeeder. The specific pin numbers are shown in Figure 2. A breakdown of the control cable is as follows:

Pins S, J, H: The auxiliary power for the wirefeeder is provided via these connections.

Pin S: 30VAC protected by 10 Amp circuit breaker.

Pin H: 115VAC protected by 5 Amp circuit breaker.

Pin J: 30VAC and 115VAC return.

NOTE

THE GREEN WIRE ON PIN G IS THE SAFETY GROUND.

Pins E, B: These pins, with corresponding wires, are used to provide remote contactor control for a wirefeeder wired for contact closure as follows:

Pin E: Contact closure provides a path to Pin B.

Pin B: Control circuit board common.

NOTE

FOR WIREFEEDERS WHICH RETURN A 115 VAC SIGNAL TO THE POWER SOURCE FOR CONTACTOR CLOSURE, A SINGLE POLE DOUBLE THROW RELAY MUST BE USED. A RELAY KIT FOR INSTALLATION INSIDE THE UNIT IS AVAILABLE FROM PowCon. Part Number 250082-001

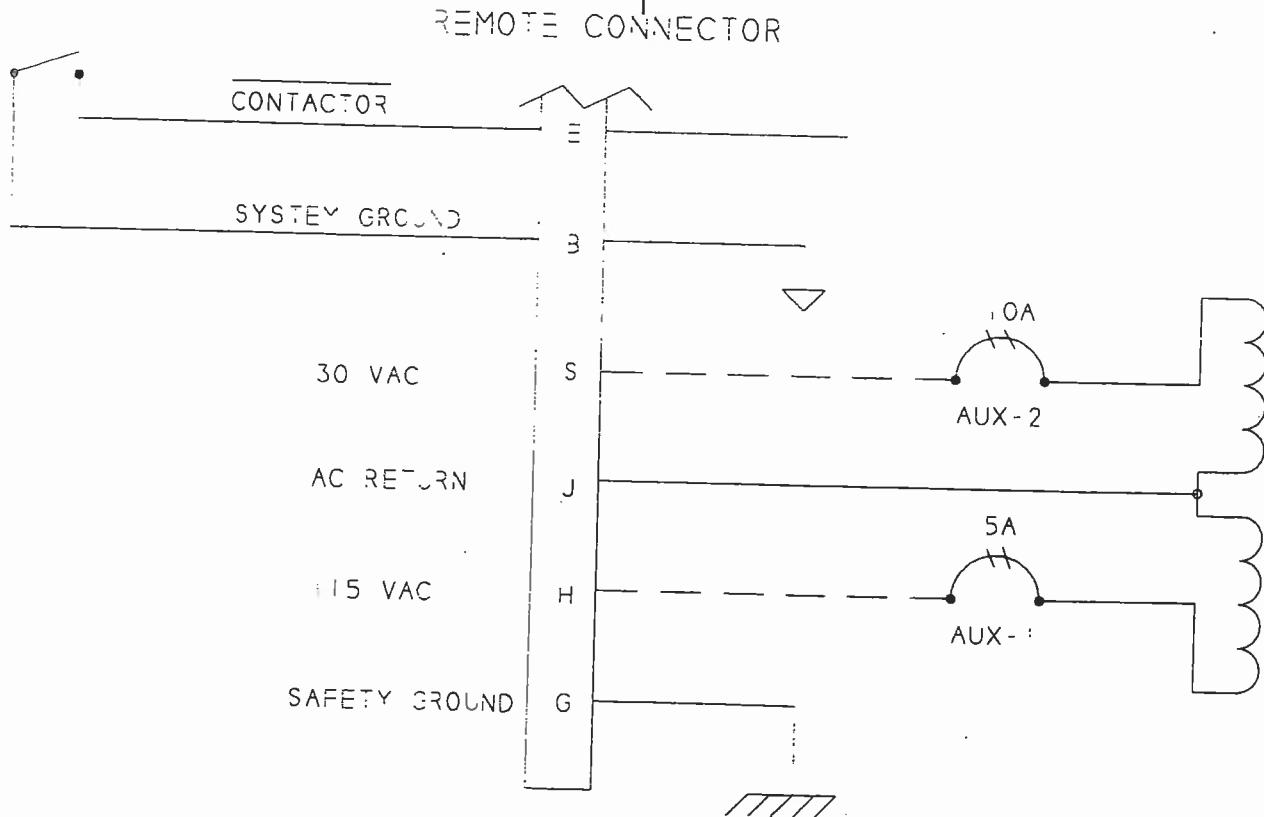

Figure 2, Wirefeeder Control Cable with Schematic

INSTALLATION

PROCEDURE FOR INPUT VOLTAGE CHANGE-OVER

The two (2) operations required to perform a primary input voltage change-over are located inside the unit (in the right back side of the welder). See Figure 3.

They are as follows:

1. Working Capacitors board.
2. Copper buss bars for main transformer.

NOTE

READ ENTIRE PROCEDURE PRIOR TO PERFORMANCE OF VOLTAGE CHANGE-OVER.



DANGER

IN ORDER TO AVOID AN ELECTRICAL SHOCK, THE UNIT MUST BE TURNED OFF AND DISCONNECTED FROM THE INPUT CIRCUIT PRIOR TO PERFORMING THE VOLTAGE CHANGE-OVER PROCEDURE.

- A. Remove the top case from the bottom case as follows:
 1. Unfasten and remove the 10 bolts and nuts holding the case together.
 2. Grab handles firmly and gently lift top case with a prying movement.
- B. Perform capacitor high voltage bleeding procedure found on page 12 before carrying out voltage changeover in the next paragraph.

WARNING

THE CAPACITORS IN THE **PowCon** WELDING POWER SOURCE ARE CHARGED WITH HIGH VOLTAGE. THE CAPACITORS WILL DISCHARGE OVER A LONG PERIOD OF TIME UNDER NORMAL SHUTDOWN PROCEDURES. HOWEVER, IN ORDER TO AVOID AN ELECTRICAL SHOCK WHEN THE CASE IS REMOVED, THE CAPACITORS MUST BE DISCHARGED BY THE USE OF A BLEEDER RESISTOR ASSEMBLY.

- C. Identify the voltage change-over instruction label (located inside top case.)

LOCATION 1: WORKING CAPACITOR BOARD CHANGE-OVER

- A. Locate the working capacitor PC board as shown in Figure 3.
- B. Remove 15 screws P1 (P1A) to P15 (P15A) locations.
- C. Position board to the desired voltage. (Input voltage reads right side up). See Figure 3.
- D. Fasten the 15 screws (max torque = 18 in/ lbs.) and insure none are missing.

LOCATION 2: MAIN TRANSFORMER CHANGE-OVER

- A. Locate TB1 on change-over mother board.

NOTE

DO NOT CHANGE THE WIRING TO THE TERMINALS CONNECTED TO THE BUSS BARS.

- B. Place buss bars for desired voltage (See Figure 3).

INSTALLATION

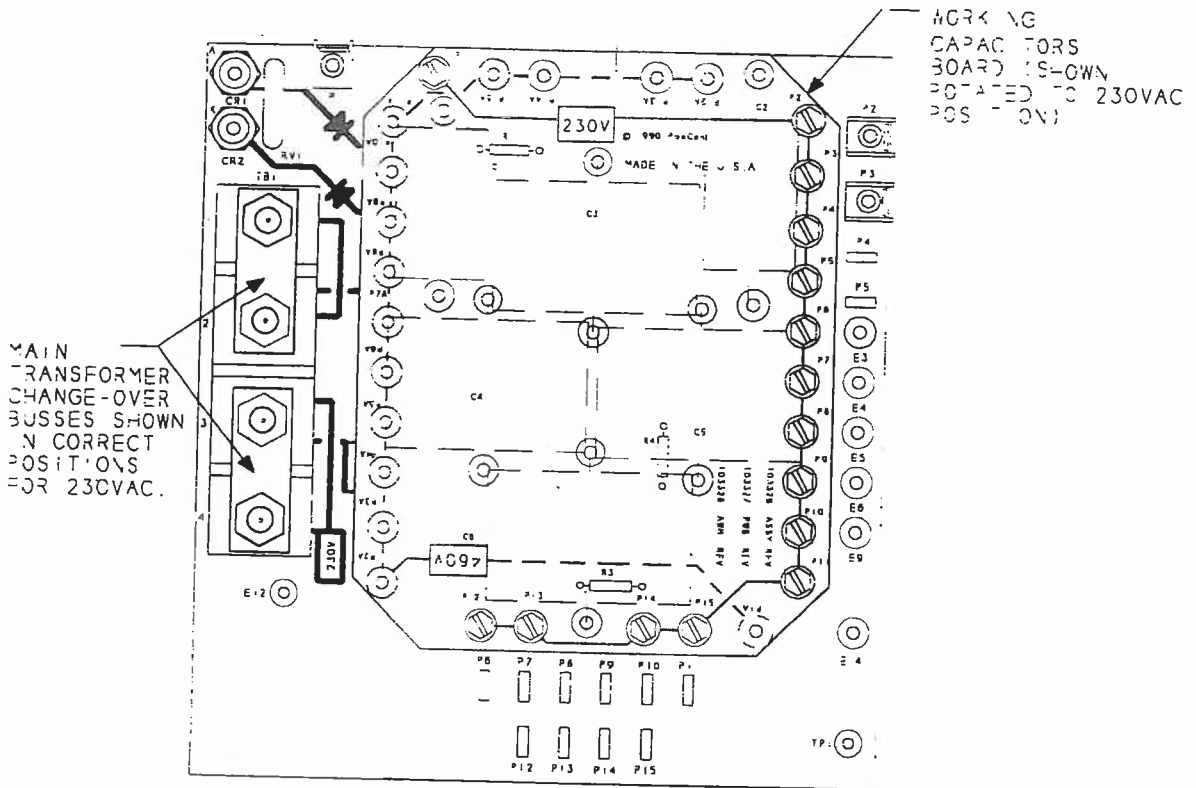

230 VAC Configuration

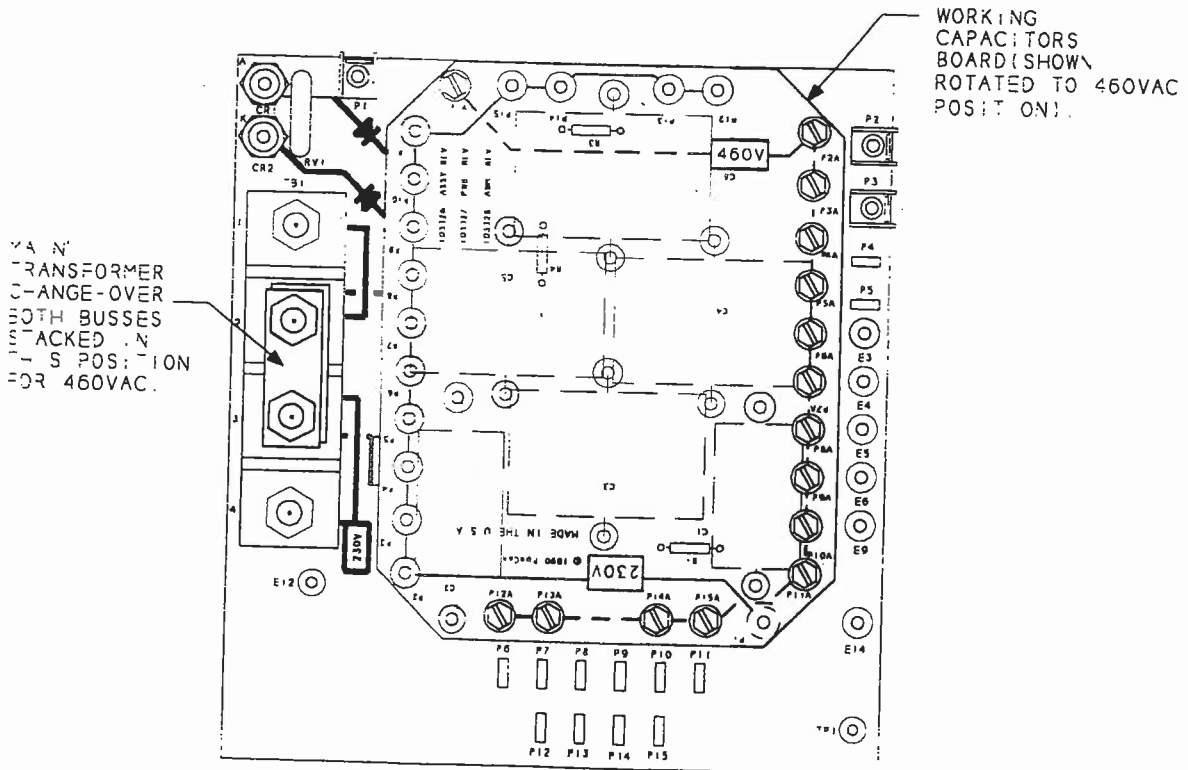

460 VAC Configuration

Figure 3, Voltage Change-Over Configurations

INSTALLATION

BLEEDER RESISTOR ASSEMBLY

CONSTRUCTION

This assembly must consist of the following components to be considered acceptable for capacitor bleed-off:

RESISTOR :Minimum requirements - 50 watts, 5 ohm.

CONDUCTOR:#16 AWG 600 VDC insulation rating.

CLIPS:#16 AWG 600 VDC insulation rating.

All connections must be hard wired (soldered). Conductors should be approximately three (3) inches in length.

The entire resistor body and the soldered connections to the resistor must be encapsulated with 600 VDC rated "heat-shrink" insulation.

A discharge resistor assembly is available from **PowCon**, P/N 250040-001. Contact your local distributor or the factory if you wish to obtain it.

USE

Once an acceptable discharge device (as described above) is available, perform the following:

NOTE

READ ENTIRE PROCEDURE PRIOR TO PERFORMING VOLTAGE BLEEDING PROCEDURE.



DANGER

DO NOT ATTEMPT TO PERFORM THIS PROCEDURE BEFORE THE POWER SOURCE IS TURNED OFF AND DISCONNECTED FROM THE PRIMARY INPUT.

- A. Locate the C.F. assembly inside the unit as shown in Figure 4. The C.F. assembly can be identified by two aluminum heatsinks which contain three diodes each.
- B. Connect one end of the bleeder resistor assembly to one of the heatsinks and attach the other end of the bleeder assembly to the other heatsink. This action will bleed the capacitors.

NOTE

A SPARK DISCHARGE MAY BE NOTICED.

- C. Leave the bleeder resistor assembly connected for at least 10 seconds.
- D. Leave one side of the resistor connected to the minus (-) side of C.F. assembly and connect the other end of the resistor for 10 seconds to P1 then P2 and P3 on change-over mother board.
- E. Remove the bleeder resistor assembly from the unit and continue with the voltage change-over.

WARNING

DO NOT ATTEMPT TO DISCHARGE THIS POWER SOURCE BY ANY OTHER MEANS THAN THAT DESCRIBED ABOVE.

INSTALLATION

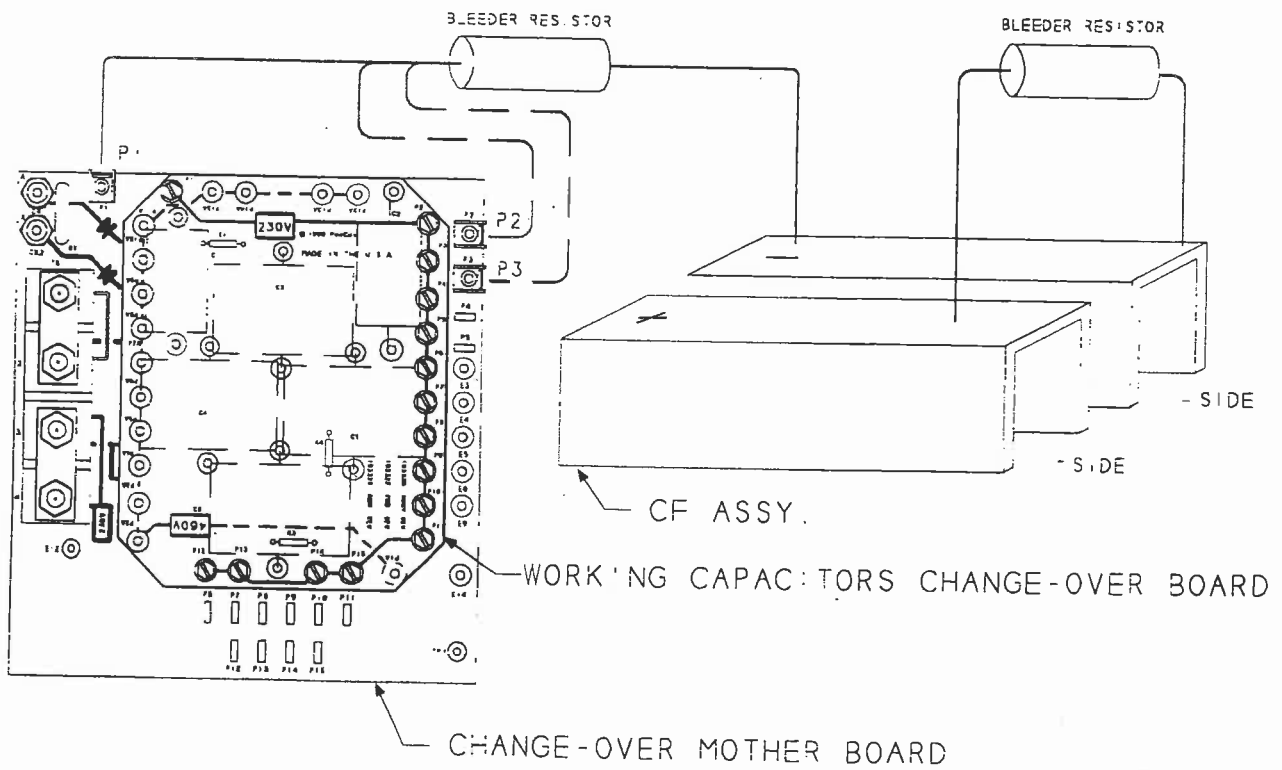
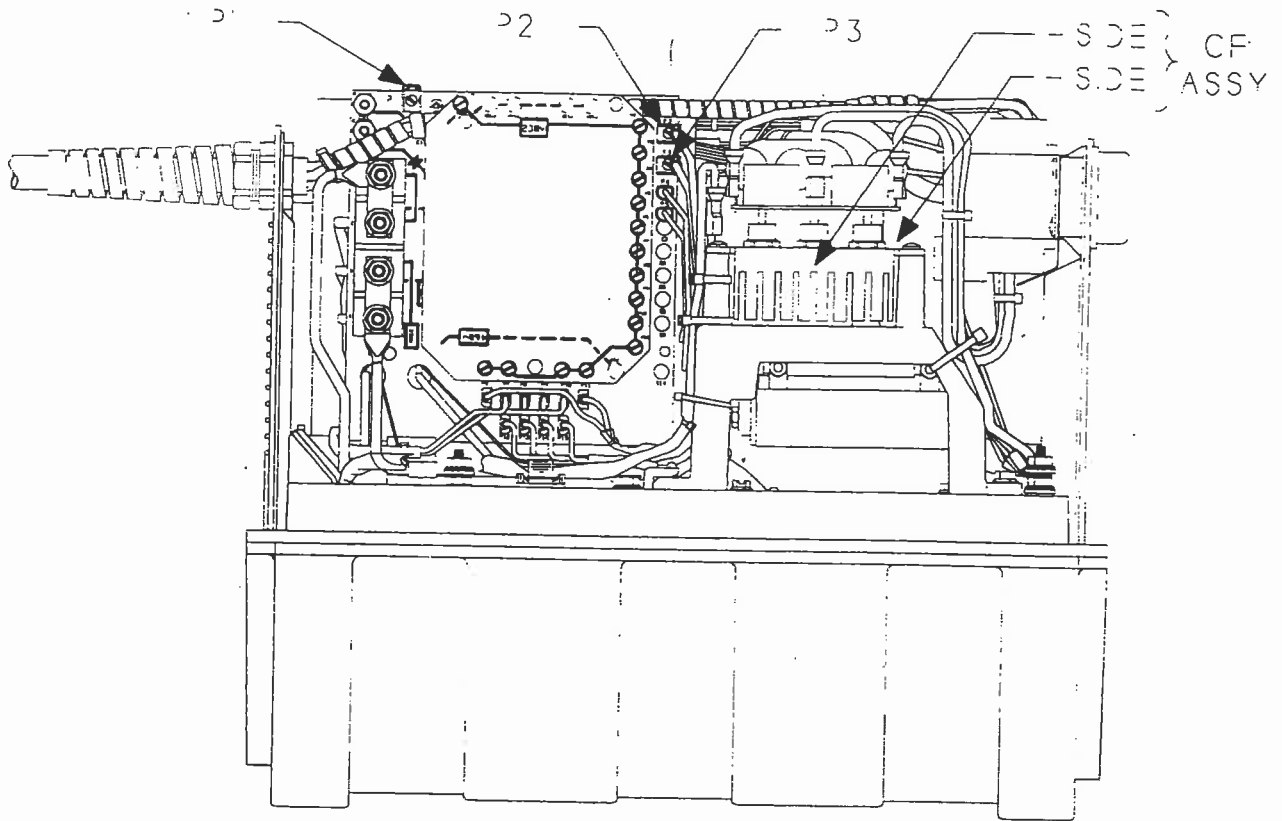

Figure 4, Bleeder Resistor Use

OPERATION

FUNCTION OF OPERATING CONTROLS AND CONNECTIONS

Bold numbers refer to Item number in Figure 5.

1. Circuit Breaker

The circuit breaker acts as a switch to turn the incoming primary power on and off, it also protects the semiconductors in the power source in the case of a fault in the control circuits. The front panel POWER indicator light should come on with the circuit breaker in the ON position.

WARNING

IN ORDER TO AVOID AN ELECTRICAL SHOCK, POTENTIAL FIRE OR EQUIPMENT MALFUNCTION, THE CIRCUIT BREAKER MUST NEVER BE FORCIBLY HELD IN THE ON (CLOSED) POSITION.

WARNING

ONCE THE CIRCUIT BREAKER IS TURNED ON, DC OUTPUT IS PRESENT IF THE CONTACTOR SWITCH 4 IS IN THE ON POSITION OR IN THE REMOTE POSITION AND A REMOTE CONTACTOR SWITCH IS ACTIVE. THIS MEANS THAT THE ELECTRODE IS LIVE AT ALL TIMES. AVOID AN ELECTRIC SHOCK.

2. AUX 1 Circuit Breaker

5 Amp circuit breaker protects 115 VAC auxiliary power to remote connector Pin H.

3. AUX 2 Circuit Breaker

10 Amp circuit breaker protects 30 VAC auxiliary power on Pin S of remote connector.

4. CONTACTOR Control Switch

WARNING

WITH THE CONTACTOR SWITCH IN THE ON POSITION THE WELDING POWER SOURCE IS ACTIVATED AND OPEN CIRCUIT VOLTAGE IS PRESENT. DO NOT TOUCH OR SHORT THE OUTPUT WELDING TERMINALS.

The contactor switch in the ON position will automatically activate the output of the welder.

The contactor switch in the REMOTE position will permit activation of the welder via a remote control device or a wirefeeder contactor switch.

5. WELD LEVEL (volts/amps) Select Switch

With the switch in the PANEL position the output volts or amps control is via the front panel potentiometer 11.

With the switch in the REMOTE position the output volts or amps control is relinquished to a remote control device via pin D of the remote connector.

6. POWER ON Indicator

A yellow light will come on when the circuit breaker 1 is in the ON position.

7. CONTACTOR ON Indicator

WARNING

WHEN THE YELLOW CONTACTOR INDICATOR IS ON THE OUTPUT OF THE WELDER IS ACTIVE. DO NOT TOUCH OR SHORT THE OUTPUT TERMINALS.

A yellow light will come on when the contactor switch 4 on the panel is in the ON position. The contactor indicator will also light when a remote control device activates the contactor function with the contactor switch 4 in REMOTE.

8. TEMPERATURE Indicator

NOTE

ON 400SMT EQUIPPED WITH "FAN ON DEMAND", THE FAN MOTOR CIRCULATES COOLING AIR INSIDE THE POWER SOURCE ONLY ON POWER-UP AND WHEN WELDING. THE FAN ON TIME DIRECTLY DEPENDS ON WELDING TIME AND SETTINGS.

If the power source duty cycle is exceeded or there is blockage of cooling air, an overtemperature condition will result and is indicated by the RED lighted TEMPERATURE indicator. While the temperature indicator is lit the welding output is disabled. Check for a blocked air inlet or exit and allow 4-6 minutes for cool down before resuming welding operations.

9. DIGITAL VOLTS/AMPS Meter

10. VOLTS/AMPS Selector Switch

Depending on the weld process selected 12 the meter will read the volts or amps preset by the output volts/amps potentiometer 11.

The meter will read (and blink) the volts preset in CV modes or the amps preset in CC modes. Upon the start of actual welding the meter reads the actual amps or volts as selected by the selector switch 10.

When welding stops, the meter will hold its last reading for 5 seconds and it then reverts to read (and blink) preset welding levels.

OPERATION

11. OUTPUT (Volts/Amps) Potentiometer

This multiturn potentiometer is used to adjust the welder output to the required weld voltage or current. The meter reads 0 to 40 VDC, preset volts in CV mode or 10 to 400 amps in CC modes. When WELD LEVEL switch **5** is in PANEL position, the potentiometer can be adjusted while welding to fine tune the arc.

When WELD LEVEL switch **5** is in REMOTE position and WELD PROCESS switch **12** is in any of the CV modes, the OUTPUT potentiometer **11** acts as an adjustable start current control, helping to eliminate spatter when feed wire comes in contact with the workpiece.

The adjustment range is from 0 to 6 VDC, as indicated by the DIGITAL VOLTS/AMPS Meter **9**. The calibration for start current is done after all other weld parameters have been set. To monitor the setting, momentarily flip WELD LEVEL switch **5** to PANEL position. Using the digital meter, calibrate for no starting current to 0 VDC, or increase the starting current incrementally up to 6 VDC until starting is spatter free.

12. WELD PROCESS Selector Switch

The four position rotary switch selects the required output for the welding process being performed.

A) GTAW (Scratch Start): Used for TIG, scratch start only. A soft arc initiation is provided by lifting the tip off the workpiece. The current will ramp to the final value as preset by the weld output potentiometer **11**. Arc force control **13** is automatically disabled.

B) CC This mode has the conventional constant current output. Output current is preset by the output weld potentiometer **11**. Arc force control for stick is provided by the arc force potentiometer **13**. Hot Start Control is provided by potentiometer at the back of the unit. (Item **17** on Figure 6). Hot start current provided for a fixed time, can be varied from none to a max of 400 amp to prevent cold stick rods from getting stuck to workpiece upon arc initiation. In auto arc-start or remote arc start TIG, arc force control and hot start control are inhibited by grounding pin K on remote connector.

C) CV Selects a constant voltage output characteristic, 0 to 40V. The output voltage is maintained at the selected level over the full output current range available from the power source. The inductance control **13** potentiometer is available for arc dynamic response.

D) CV/Slope selects a constant voltage output. The actual welding arc voltage will decrease from selected value at a rate of 3V for each 100 amps of welding current; the slope is 3V/100A.

Example: 22VDC is preset for GMAW short arc transfer. Wire speed will create a current value of 133 amps. The final arc voltage will be less 3V for 100A plus 1V for 33 amps. Final arc voltage will be 22VDC - 3V - 1V = 18.0V. Slope is used to control peak currents value during short arc and provides spatter control. The inductance control potentiometer **13** is provided for arc dynamic response adjustments.

13. (CV) Inductance/(CC) Arc Force Control

A) (CV) Inductance control operates as an adjustment of heat input and controls puddle fluidity in the CV-GMAW process. With minimum inductance selected, the arc is fast responding (drop frequency is high) and weld beads are well defined.

With increasing inductance the arc response is lower, spatter is minimized, and the weld beads are more fluid on the workpiece.

B) (CC) Arc force control operates only in CC mode and prevents the rods used in the SMAW (stick) process from getting stuck to the workpiece.

When turned fully clockwise, the short circuit current is about 200 amps larger than the set current level. Turning the control to 5, the short circuit current is about 100 amps larger than the set current. With the control on 0 (zero) there is no change in the current value initially selected. As a rule of thumb, the bigger the rod diameter the more the arc force that should be dialed in.

14. & 15. Output Terminals

Quick connect female output receptacles with polarity as marked. The user must supply cable and male connect plugs. See the Installation Section for the recommended cable size.

OPERATION

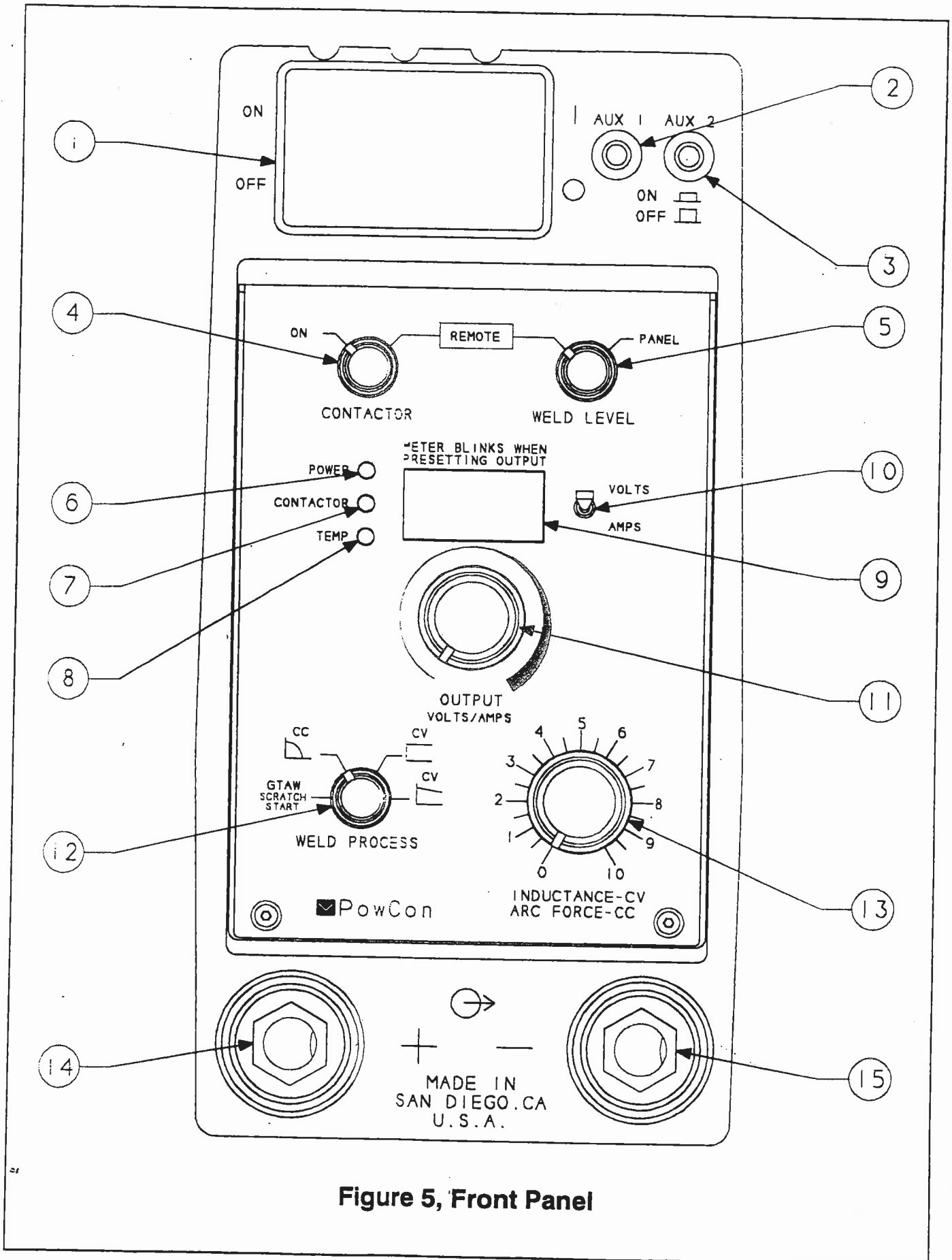
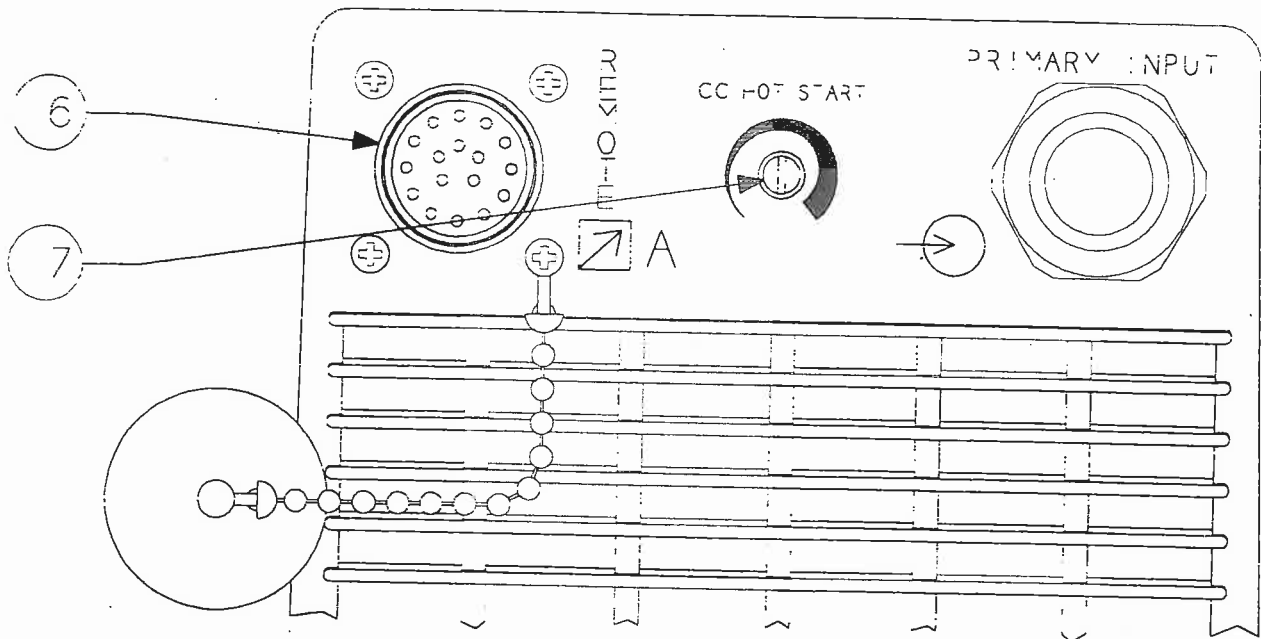

Figure 5, Front Panel

OPERATION

Figure 6, Rear Panel



16. Remote Connector

This is the connection for remote contact closure and is the auxiliary power connection for a wirefeeder. It can also be used with remote control devices:

The following list is the functional designation of the pins:

Terminal A: +24 VDC out, 100 mA maximum from the control board. Used to power remote control devices.

Terminal B: Control board common; used with remote control devices.

Terminal C: Weld level output; 0-4ma, current loop transmitter.

Terminal D: Weld level input; 0-4ma, current loop receiver.

Terminal E: Contactor input; will energize the welding power source when a dry contact closes to pin B.

Terminal F: Error amplifier enable; active low signal for use with remote V/I control devices.

Terminal G: Chassis common; safety ground.

Terminal H: 115VAC, with respect to pin J protected by 5A circuit breaker on the front panel.

Terminal J: 30VAC and 115VAC return.

Terminal K: Arc force inhibit; an active low signal will disable the arc force control on the front panel. Used with remote control devices.

Terminal L: Spare

Terminal M: Slope #2; active low signal used with remote control devices.

Terminal N: Amperage output signal; 0-4mA current loop transmitter.

Terminal P: Voltage output signal; 0-4mA current loop transmitter.

Terminal R: Blank/Accel commands; logic level signals used with remote control devices.

Terminal S: 30VAC, with respect to pin J. Protected by 10 amp circuit breaker on the front panel.

Terminal T: "B" sync output; an active low signal for use with remote voltage/current control devices.

17. Hot Start Control Potentiometer

Provides current for a fixed time, which can be varied from none to a max of 400 amps to prevent cold stick rods from getting stuck to workpiece upon arc initiation.

OPERATION

DUTY CYCLE

NOTE

ON 400SMT EQUIPPED WITH "FAN ON DEMAND" - THE FAN MOTOR CIRCULATES COOLING AIR INSIDE THE POWER SOURCE ONLY ON POWER-UP AND WHEN WELDING. THE FAN ON TIME DIRECTLY DEPENDS ON WELDING TIME AND SETTINGS.

The duty cycle of a welding power source is a measure of the capacity of the unit. The PowCon 400SMT has a duty cycle based on a 10 minute time period. The duty cycle is the percent of that time period the unit can produce the specified output.

The PowCon 400SMT can operate for 6 minutes out of a 10 minute period at an output of 300 amperes and 32 volts. To assure the safe operation of the unit, the remaining 4 minutes must be spent idling to permit proper cooling. The duty cycle at this output is 60%.

Lowering the output current allows increases in the duty cycle. Thus the 100% duty cycle (weld output continuous) is 250 amperes and 30 volts.

NOTE

FAILURE TO ALLOW THE UNIT TO IDLE FOR THE REQUIRED PERIOD OF DUTY CYCLE WILL ACTIVATE THERMAL OVERLOAD DEVICES. IF THESE DEVICES ARE ACTIVATED, THE UNIT WILL SHUT DOWN UNTIL THE COMPONENTS ARE SUFFICIENTLY COOLED

OPTIMUM CAG PERFORMANCE

NOTE

TO PREVENT FAILURE OF OUTPUT CAPACITOR: FOR PROLONGED AND FREQUENT USERS OF CAG WE RECOMMEND THE INSTALLATION OF A TEMPERATURE MONITORING AND DUTY CYCLE LIMITING DEVICE ON THE OUTPUT CAPACITOR. (ORDER KIT # 250106)

- Set the 400SMT in CV-Slope mode
- Preset Weld level to maximum (40 volts)
- Turn Contactor switch to ON

This will provide the operator with a smooth gouging-arc using up to 5/16 diameter rods.

If long cables are used or more output is required, use a remote hand control, such as RH110D/RH100C. With the Weld level switch in remote position, the RH110D/RH100C will increase voltage preset range up to approximately 49 volts, giving more power in the arc.







400SMT	
WELD PROCESS GUIDE	
	RECOMMENDED USE
GTAW	<ul style="list-style-type: none"> • TIG SCRATCH START • OPTION: -PULSER
	<ul style="list-style-type: none"> • SMAW • OPTIONS: -TIG ARC STARTER -STARCUT -PULSER
	<ul style="list-style-type: none"> • GMAW-SPRAY • FCAW • OPTION: -MIG PULSER
	<ul style="list-style-type: none"> • GMAW- SHORT CIRCUIT • CAG • FCAW • OPTIONS: -MIG PULSER
	INDUCTANCE-CV ARC FORCE-CC
CV-INDUCTANCE CONTROL	
<ul style="list-style-type: none"> • USE WITH GMAW SHORT CIRCUIT TRANSFER 	
CC-ARC FORCE CONTROL	
<ul style="list-style-type: none"> • USE WITH SMAW 	
	OUTPUT CONTROL
<ul style="list-style-type: none"> • PRESET CURRENT IN GTAW AND CC MODES • PRESET VOLTAGE IN CV MODES 	

Figure 7, Weld Process Guide

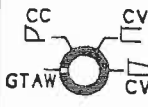
MAINTENANCE

SERVICE

WARNING

ON FAN ON DEMAND EQUIPPED UNITS, SHOULD THE FAN NOT ROTATE AND GENERATE A FAMILIAR SOUND, ENSURE THAT THE POWER SOURCE IS OFF AND DISCONNECTED FROM INPUT POWER BEFORE PERFORMING ANY KIND OF MAINTENANCE.

Unauthorized service to this unit by anyone other than a PowCon trained and authorized technician will void the limited warranty.

INTERNAL CLEANING

The use of a PowCon unit in an environment containing airborne dust and dirt requires occasional blowing out or vacuuming of the unit. The frequency of the cleaning operation is dependent upon the severity of the environment. Use only clean, dry air or vacuum suction to clean the unit.

EXTERNAL TROUBLESHOOTING

If the PowCon power source malfunctions, the following Troubleshooting Guide will be helpful in locating the problem. This guide covers only malfunctions that can be located and corrected without opening the unit.

- A) Before doing anything else, make sure that the unit is connected to the correct voltage and that all three legs of the three phase power cable are connected.
- B) Make sure that the unit is properly grounded.
- C) The circuit breaker on the front panel is intended to trip in the event of a fault or component failure in the unit. It does not trip if the unit overheats; the control circuit automatically turns the output off until it cools down. If the circuit breaker trips it is probable that a fault has occurred. It may be reset ONCE to see if it was a momentary fault.

NOTE

REPEATED RESETTING OF THE CIRCUIT BREAKER ONLY INCREASES THE CHANCE OF CAUSING ADDITIONAL FAILURES TO THE UNIT.

- D) With no load connected, turn the unit on and switch contactor switch to ON. A "ticking" sound should be heard.

GENERAL TROUBLESHOOTING

Welding current too low for power setting.	Phase missing primary power.	Check primary connections.
Unit shuts down while welding. Fan still rotates and power and temperature lights are ON.	Unit overheated due to: A. Running too high amperage. B. Improper cooling of unit.	Wait 10 minutes. Reduce the welding current and duty cycle. Make sure the air vents are not obstructed.
No wirefeed when gun trigger engaged.	Poor contactor connection. Lack of auxiliary power to wirefeeder.	Check remote connections on both PowCon and wirefeeder. Check AUX 1 and AUX 2 Circuit Breaker.
No weld current for SMAW.	Contactor switch in remote position.	Turn contactor switch to ON.
Weld control erratic for application.	Wrong mode on process switch.	Change as required.

INTERNAL TROUBLESHOOTING

An input voltage change-over is the only internal service that can be performed by other than a PowCon trained and authorized technician. The input voltage change-over procedure is detailed on Page 10 of this manual. No other reason exists for unauthorized personnel opening the case of the unit.



DANGER

BEFORE PERFORMING INPUT VOLTAGE CHANGE-OVER, AN UNDERSTANDING OF THE PROCEDURE ON PAGE 10 OF THIS MANUAL IS REQUIRED. THE CAPACITORS IN THIS UNIT CAN HOLD A DANGEROUS CHARGE EVEN WHEN THE PRIMARY POWER IS DISCONNECTED. TO DISCHARGE THESE CAPACITORS, USE THE BLEEDER TYPE RESISTOR ASSEMBLY PROCEDURE OUTLINED ON PAGE 12 & 13 FOR INPUT VOLTAGE CHANGE-OVER.

DRAWINGS & PARTS LISTS

Side View Parts List, Figure 8

1	1	250018-005	Kit, Replacement Case Top - 400SMT	
2	2	250017-002	Handle Kit	
3	1	103436-001	Assembly, Aux Transformer 30-115-48V Fan On Demand	T3
	1	103399-001	Assembly, Aux Transformer 30-115V Non Fan On Demand	T3
4	3	902011-007	Varistor	RV2-4
5	2	900000-001	Input Capacitor	C1, 2
6	1	100148-002	Input Cap Bracket with PTC	
7	1	103350-001	Mount, CF Assembly	
8	1	103315-002	Front Panel Silkscreened	
9	1	100345-001	Chassis	
10	1	103432-001T	Assembly, Front Panel Interface PWB Fan On Demand	
	1	103355-003T	Assembly, Front Panel Interface PWB Non Fan On Demand	
11	1	103413-001	Rear Panel Silkscreened	
12	1	103428-001T	Assembly, Control PWB Fan On Demand	
	1	103428-003T	Assembly, Control PWB Non Fan On Demand	
13	2	103366-001	Fan Bracket	
14	1	922001-004	Fan Blade	
15	1	103437-001	Assembly, 48V Fan Fan On Demand	T1
	1	100358-001	Assembly, Fan Transformer Non Fan On Demand	T1
16	2	103366-002	Fan Bracket	
17	1	100379-001T	Assembly, Diode Heatsink	CR2, 3
18	1	100006-001	Case Bottom	
19	1	103332-002	Assembly, Main Inductor	L1
20	1	103335-002	Assembly, Hall Effect PWB	

DRAWINGS & PARTS LISTS

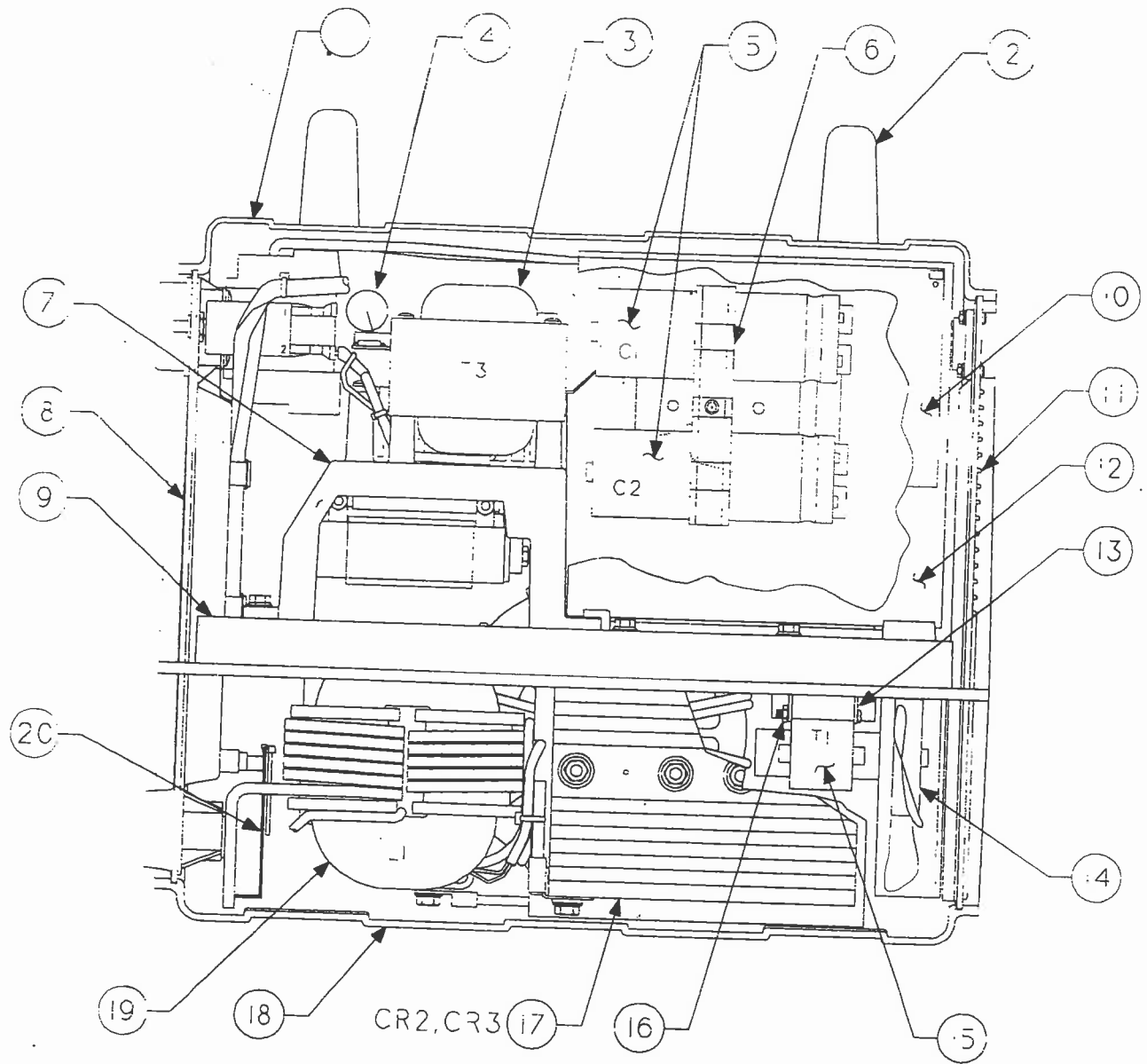

Figure 8, Side View

DRAWINGS & PARTS LISTS

Top View Parts List, Figure 9

Item	Qty	Part No.	Description	
1	1	100345-001	Chassis	
2	1	921000-001	Circuit Breaker	CB1
3	1	100199-001	Assembly, CF PWB 230/460V	
4	3	902011-007	Varistor	RV2-4
5	3	912000-002	Diode, Cathode Stud	CR1-3
6	3	912000-001	Diode, Anode Stud	CR4-6
7	1	103326-001	Assembly, Cap PWB	
8	1	103322-002	Assembly, Mother PWB	
9	1	103432-001T	Assembly, Front Panel Interface PWB Fan On Demand	
	1	103355-003T	Assembly, Front Panel Interface PWB Non Fan On Demand	
10	1	103428-001T	Assembly, Control PWB Fan On Demand	
	1	103428-003T	Assembly, Control PWB Non Fan On Demand	
11	1	100177-002	Chassis, Capacitor	
12	1	103436-001	Assembly, Aux Transformer 30-115-48V Fan On Demand	T3
	1	103399-001	Assembly, Aux Transformer 30-115V Non Fan On Demand	T3
13	1	921013-001	Circuit Breaker 5 Amp	CB2
14	1	921013-002	Circuit Breaker 10 Amp	CB3
15	1	103376-001	Assembly, COM Inductor - Left	L3
16	1	103377-001	Assembly, COM Inductor - Right	L4
17	1	902003-002	Power Resistor, 40 OHM 100W	R5
18	1	250097-001	Assembly, Varistor Kit	RV5-7
19	1	902011-009	Varistor	RV1
20	1	912002-001	Diode, Anode Stud	CR1
21	1	912002-002	Diode, Cathode Stud	CR2

DRAWINGS & PARTS LISTS

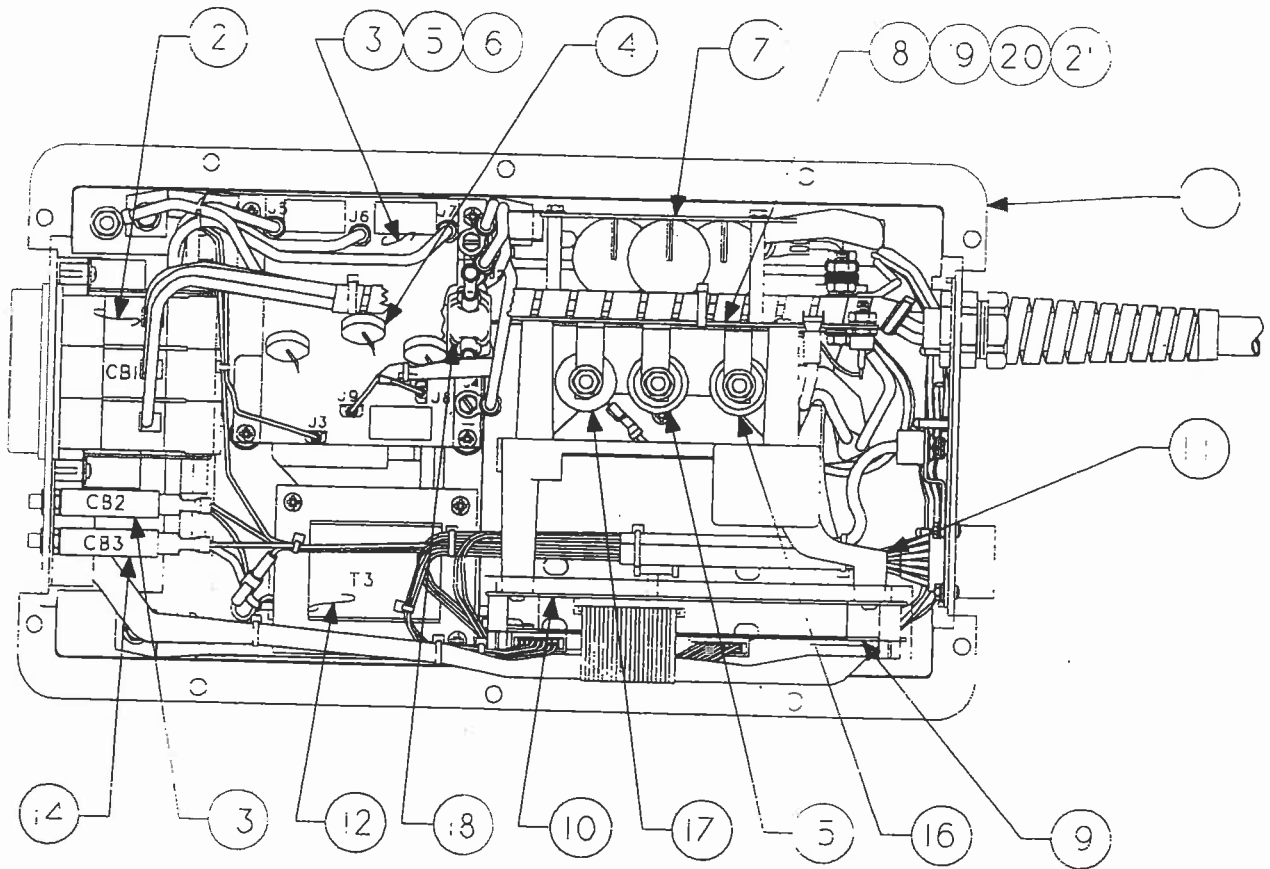

Figure 9, Top View

DRAWINGS & PARTS LISTS

Bottom View Parts List, Figure 10

Part No.	Qty	Part No.	Description	Reference Designator
1	1	100345-001	Chassis	
2	1	103332-002	Assembly, Main Inductor	L1
3	1	103364-001	Assembly, Diode/Heatsink	CR1
4	1	100353-001	Assembly, Main Transformer 230/460V	T2
5	1	100379-001T	Assembly, Diode Heatsink	CR2, 3
6	1	103344-001	Assembly, Snubber	R4, C4
7	1	100330-001T	Assembly, Range Change Heatsink	CR7, 8 Q1, 2
8	1	100384-001T	Assembly, SCR Heatsink	QA, QB
9	1	103437-001	Assembly, 48V Fan Fan On Demand	T1
	1	100358-001	Assembly, Fan Non Fan On Demand	T1
10	1	922001-004	Fan Blade	
11	2	100339-002	Bracket, Range Change Heatsink	
12	1	103331-002	Assembly, Output Inductor	L2
13	1	900001-004	Cap, AL EL 1.5 uF 100VDC	C3
14	1	989010-002	Clamp, Capacitor - 2.50 ID	

DRAWINGS & PARTS LISTS

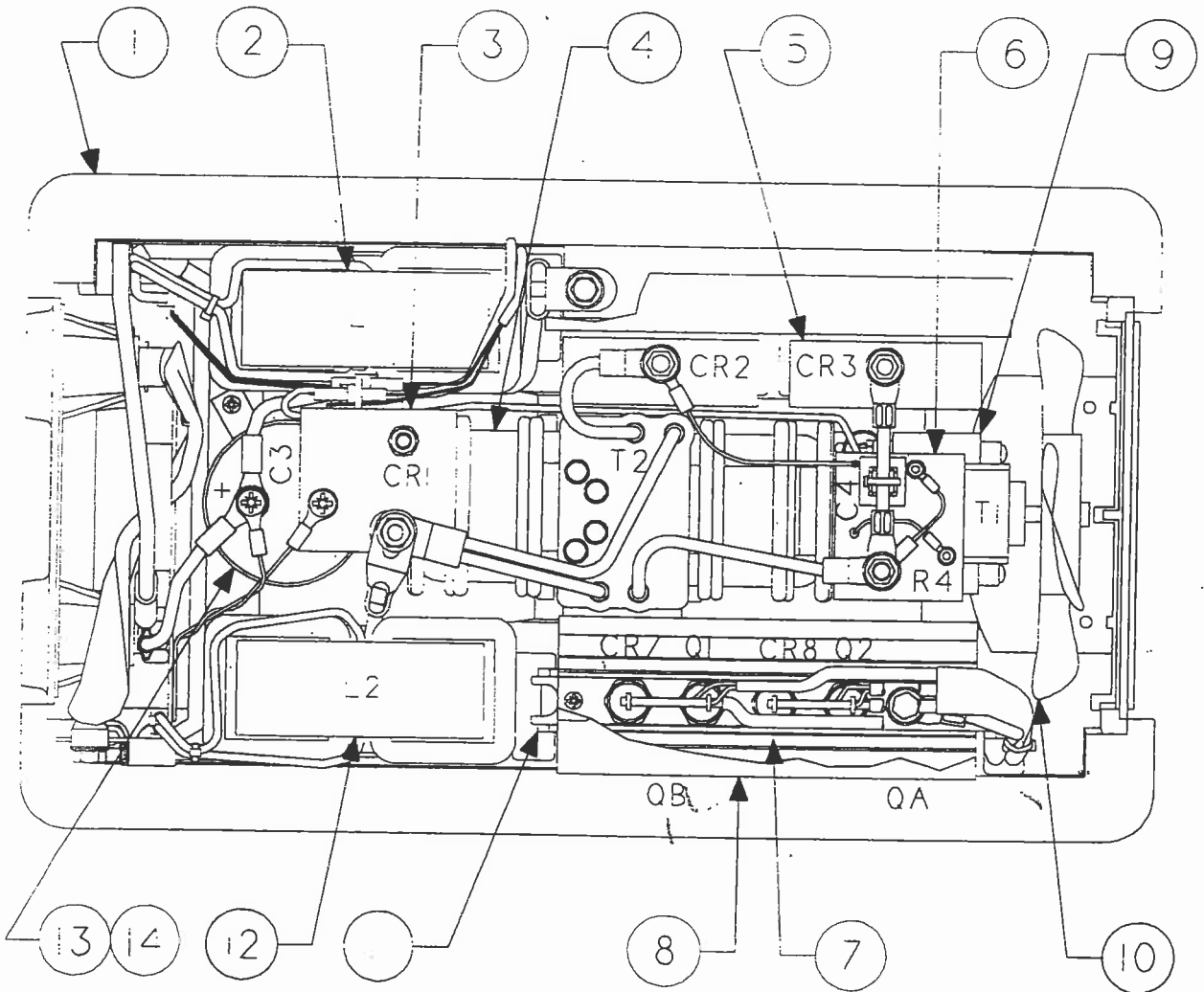

Figure 10, Bottom View

DRAWINGS & PARTS LISTS

Front Panel Parts List, Figure 11

1	1	921000-001	Circuit Breaker	CB1
2	1	100030-001	Bracket, Circuit Breaker	
3	1	100005-001	Boot, Circuit Breaker	
4	1	921013-001	Circuit Breaker - 5 Amp	CB2
5	1	921013-002	Circuit Breaker - 10 Amp	CB3
6	1	103315-002	Front Panel, Silkscreened	
7	1	250002-001	Kit, Output Jack Hardware	
8	2	100025-001	Output Jacks - Tweco	
OPT	2	100028-001	Output Jacks - Dinse	
9	1	250109-001	Kit, Control Panel	
11	1	103351-001	Assembly, DVM PWB	
12	1	920009-002	Switch Toggle SPDT	SW4
13	2	920019-003	Switch, Rotary, 1 Pole, 2 Position	SW2, 3
14	1	920019-004	Switch, Rotary, 1 Pole, 4 Position	SW1
15	3	940024-001	Knob, Small	
16	1	903002-011	Potentiometer, 10K	R1
17	1	903010-001	Potentiometer, Dual 10K	R2
18	2	940024-101	Knob, Large	

DRAWINGS & PARTS LISTS

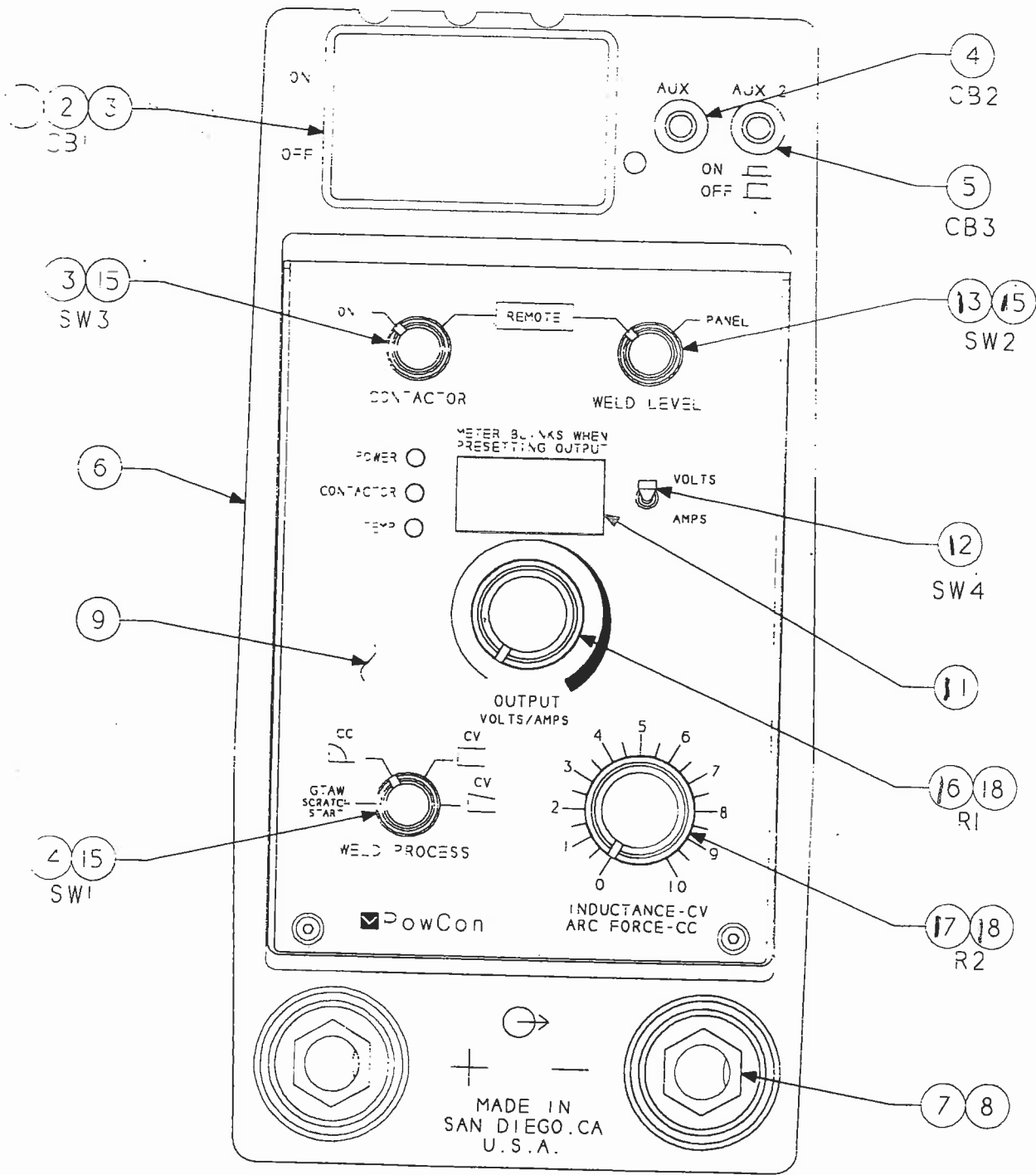

Figure 11, Front Panel

DRAWINGS & PARTS LISTS

Rear Panel Parts List, Figure 12

Item	Qty	Part No.	Description	Ref
1	1	930014-004	Connector	J1
2	1	930014-502	Cap, Sealing	
3	1	940015-003	Strain Relief with Nut	
4	1	103413-001	Rear Panel, Silkscreened	
5	1	103417-001	Assembly, CC Hot Start Bracket	R6

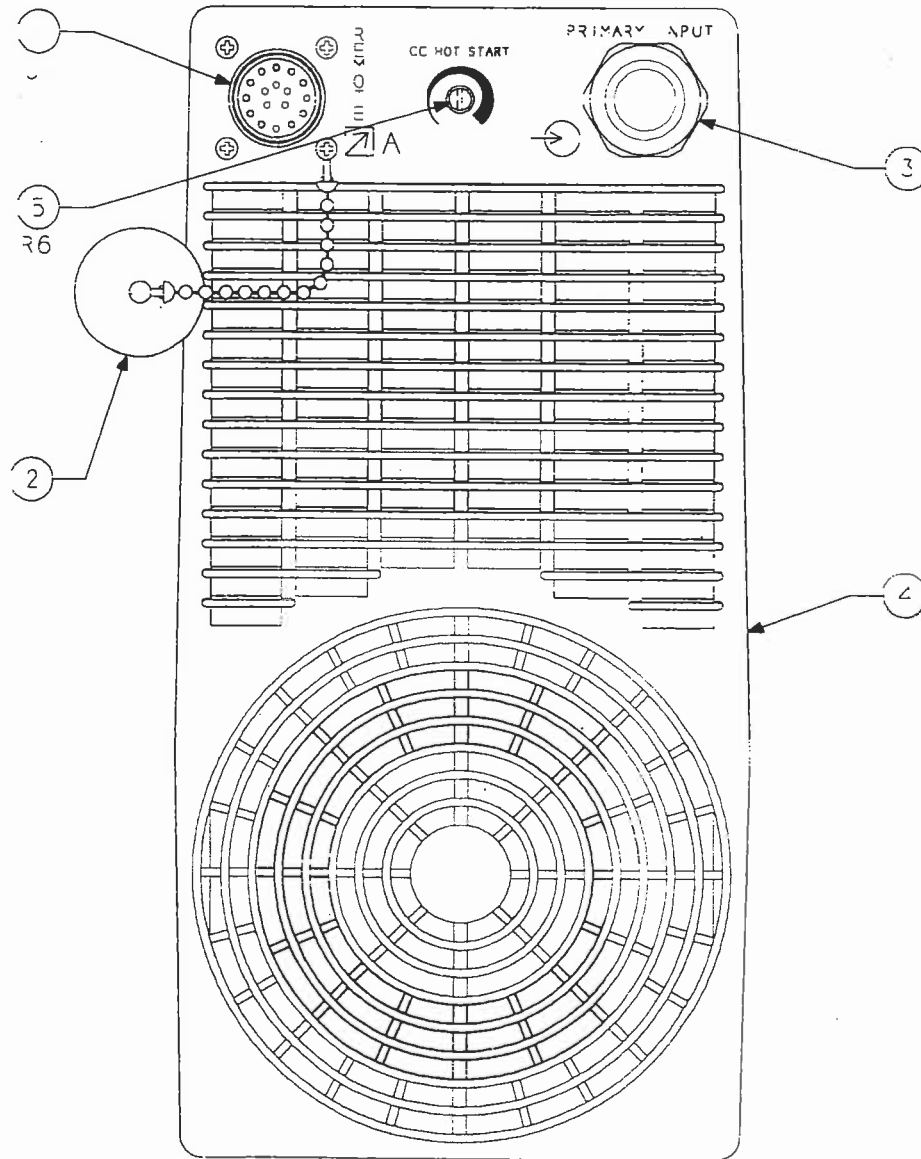

Figure 12, Rear Panel

DRAWINGS & PARTS LISTS

Front View Parts List, Figure 13

Front View Parts List, Figure 13				
1	1	100199-001	Assembly, C.F. PWB 230/460V	
2	1	103436-001	Assembly, Aux Transformer 30-115-48V Fan On Demand	T3
	1	103399-001	Assembly, Aux Transformer 30-115V Non Fan On Demand	T3
3	2	250017-002	Handle Kit	
4	3	902006-001	Surge Resistor	R1-3
5	1	103332-002	Assembly, Main Inductor	L1
6	1	103331-002	Assembly, Output Inductor	L2
7	1	900001-004	Cap, AL EL 1.5Kuf 100VDC	C3
8	1	989010-002	Clamp, Capacitor - 2.50 ID	
N/A	1	103420-001	Data Label 230/460V 400SMT	

DRAWINGS & PARTS LISTS

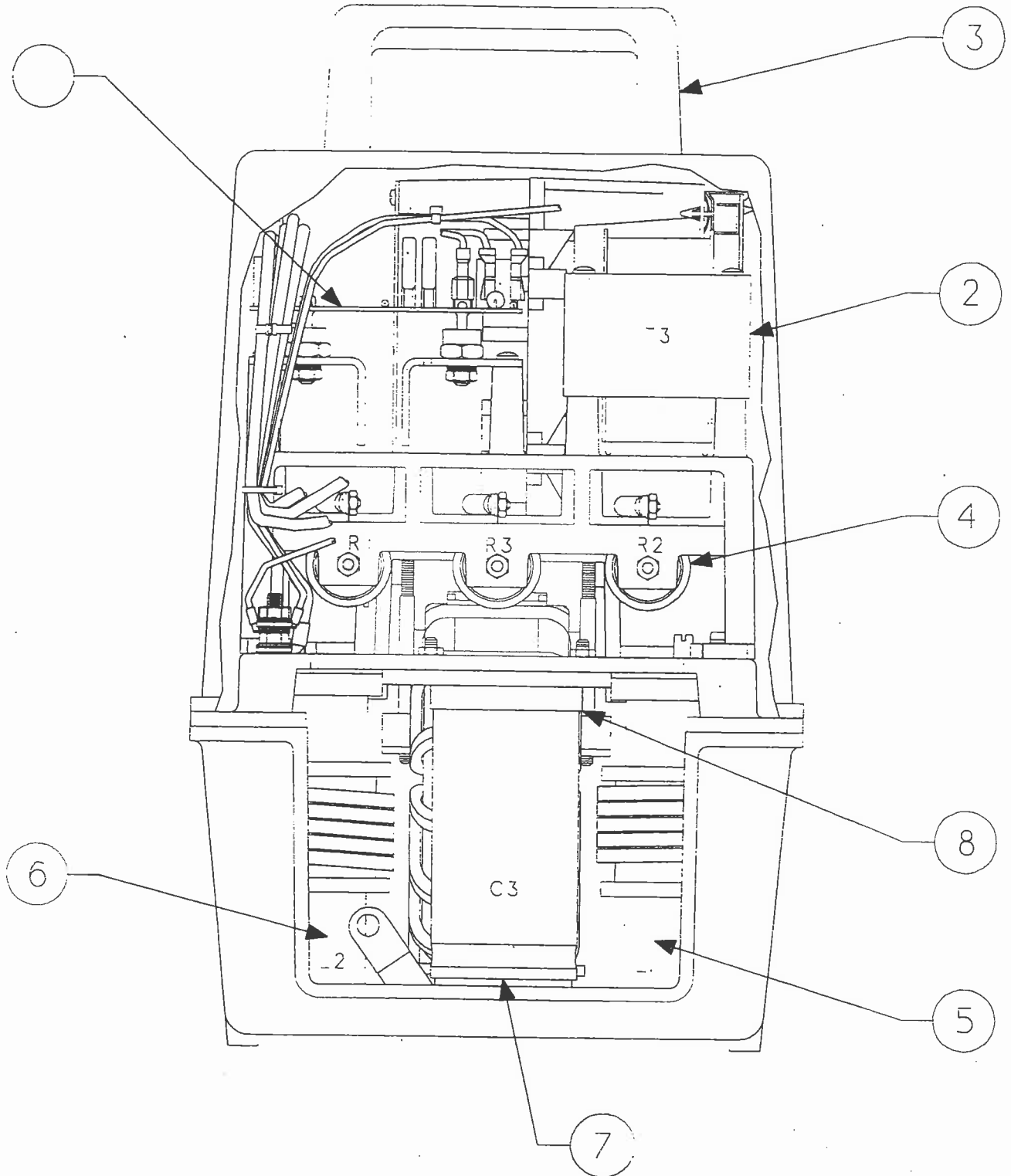
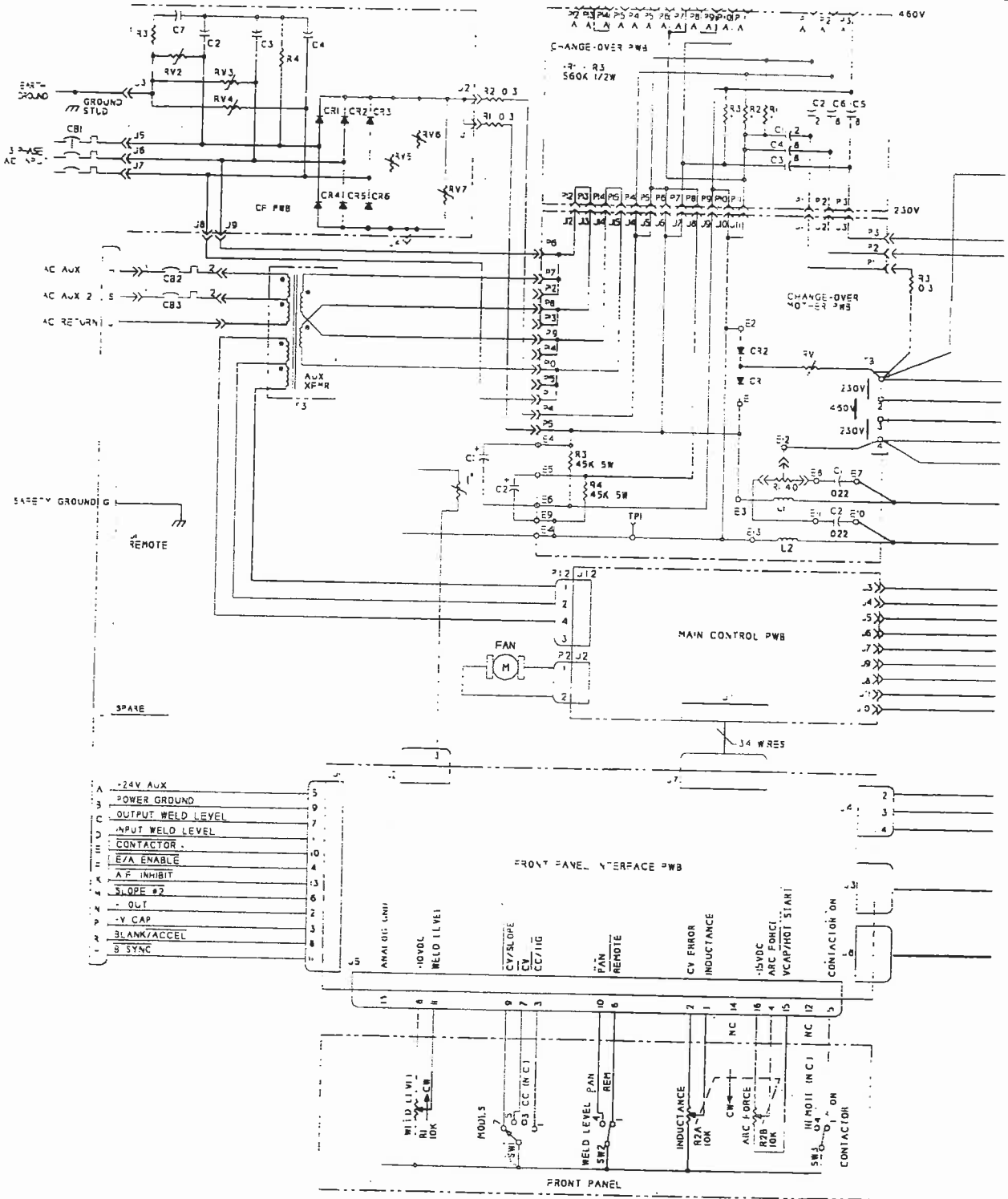
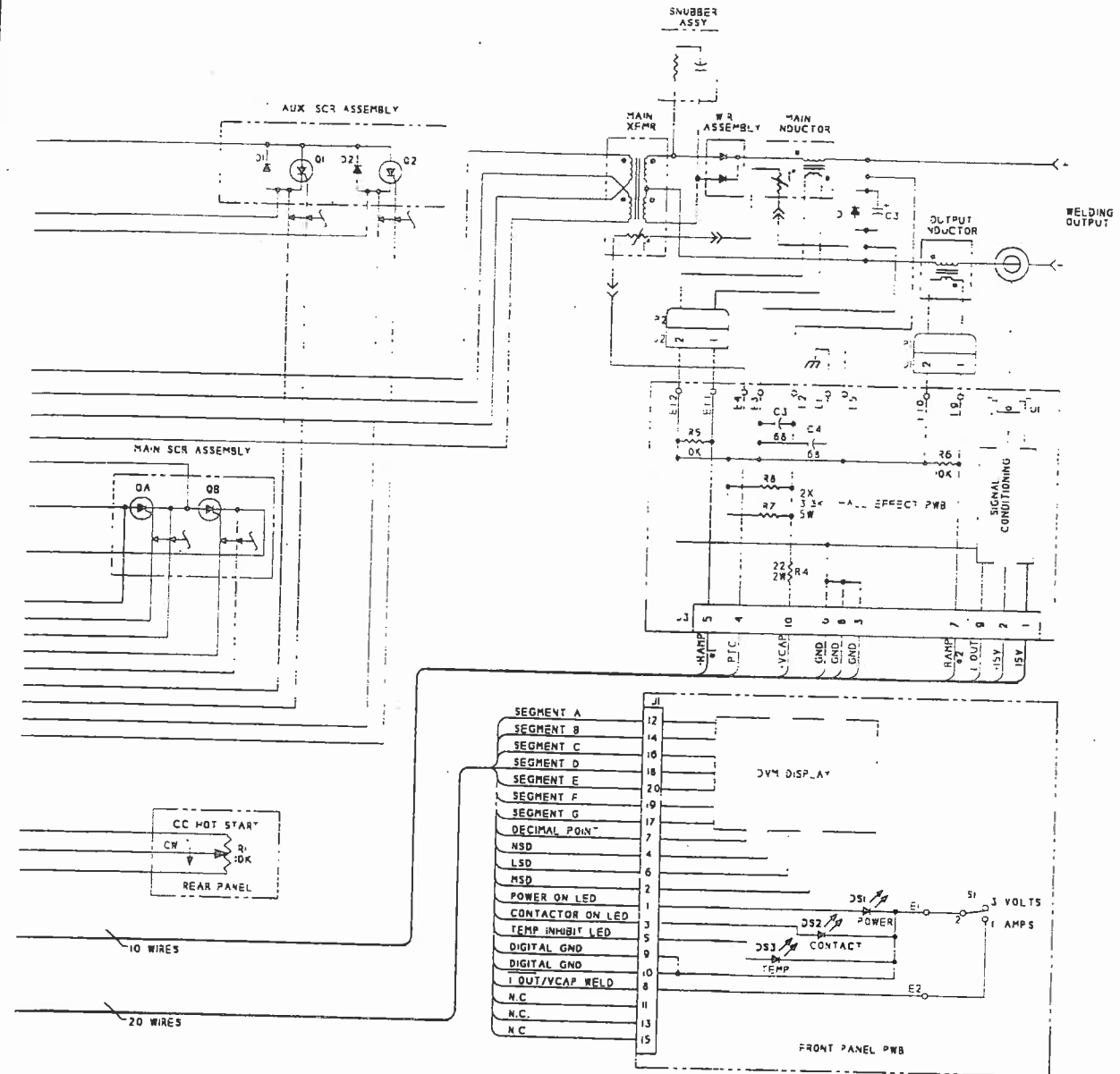

Figure 13, Front View

SCHEMATIC, FAN ON DEMAND



SCHEMATIC, FAN ON DEMAND



SCHEMATIC, NON FAN ON DEMAND

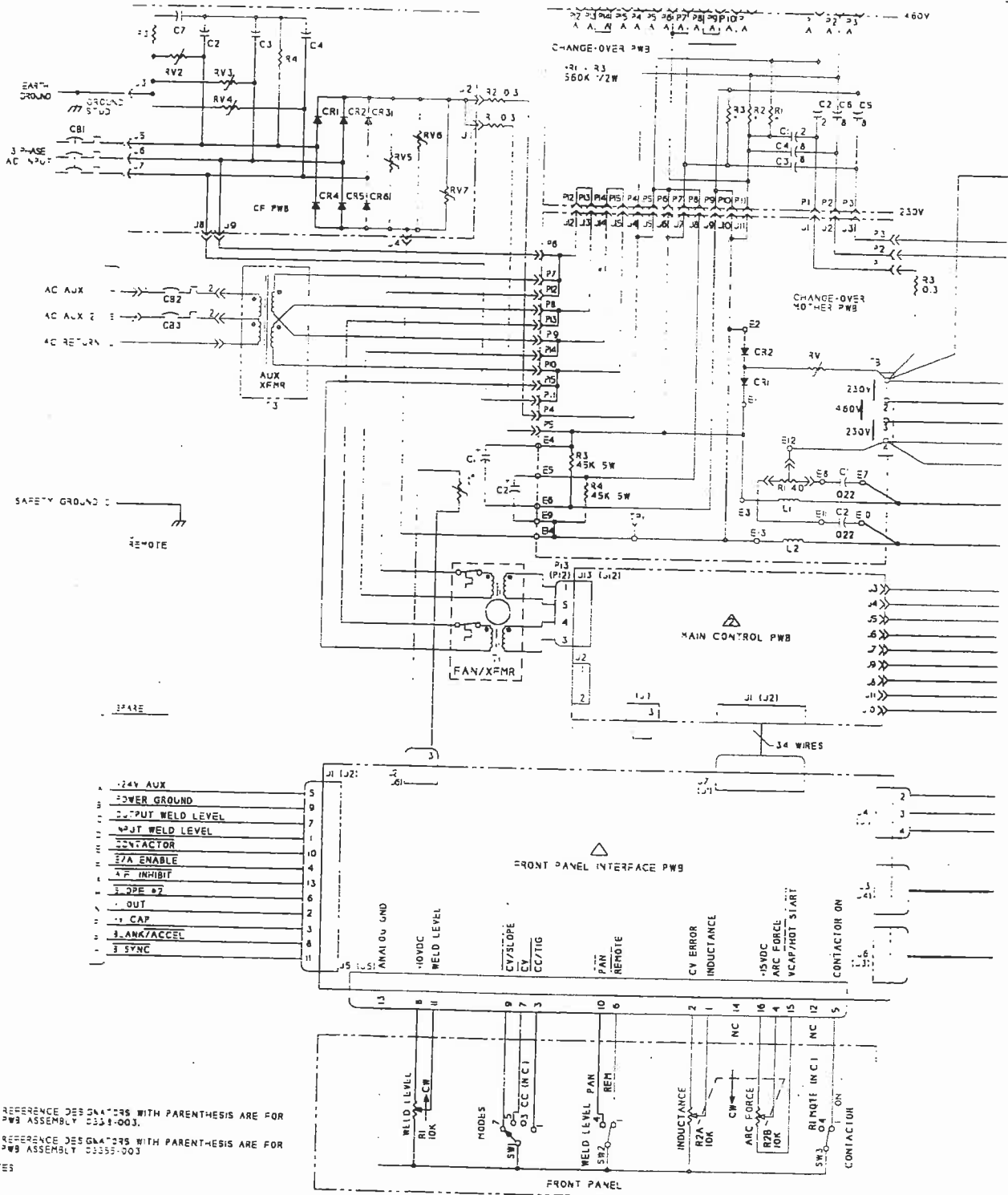

⚠ REFERENCE DESIGNATORS WITH PARENTHESIS ARE FOR PWB ASSEMBLY 0334-003.
 ⚠ REFERENCE DESIGNATORS WITH PARENTHESIS ARE FOR PWB ASSEMBLY 0335-003.
 NOTES

SCHEMATIC, NON FAN ON DEMAND

