



**! IMPORTANT !**  
-FOR YOUR SAFETY-  
READ THIS MANUAL BEFORE  
INSTALLING OR USING EQUIPMENT

# OPERATION MANUAL

Effective commencing Serial Number SS 2013 TH

# 300SS

# TABLE OF CONTENTS

## **SAFETY**

Definitions .....	1
Safety Information .....	1
Electric Shock .....	1
Personal Protection .....	2
Fire Safety .....	2
Ventilation .....	3
Safety References .....	3
French Translation .....	4 - 7

## **GENERAL INFORMATION**

Description of Equipment .....	8
Specifications .....	8
Accessories .....	8
Theory of Operation .....	8
Special Safeguards for Use with the PowCon300 .....	9

## **INSTALLATION**

Unpacking New Equipment .....	10
U.L. Requirements .....	10
Equipment Installation .....	10
Fuse Size .....	10
Primary Wire Size .....	11
Single Phase Installation .....	11
Three Phase Installation .....	11
Engine Driven Generator Use .....	11
Location of Equipment .....	12
Cooling .....	12
Access .....	12
Lifting .....	12
Security .....	12
Output Connections .....	12
Welding Cable .....	12
Remote Current and Contactor Control Connections .....	13
Procedure for Input Voltage Change-Over .....	13
Location 1: Working Capacitor Filter Board Change-Over .....	14
Location 2: Main Transformer Change-Over .....	14
Location 3: Fan Transformer Change-Over .....	14
Bleeder Resistor Assembly .....	14
Construction .....	14
Use .....	15

## **OPERATION**

<b>Function of Operating Controls and Connections</b> .....	<b>18</b>
<b>Circuit Breaker</b> .....	<b>18</b>
<b>Indicator Lamp</b> .....	<b>18</b>
<b>Range Switch</b> .....	<b>18</b>
<b>Weld Power Control Dial</b> .....	<b>18</b>
<b>Remote Control</b> .....	<b>18</b>
<b>Primary Control</b> .....	<b>18</b>
<b>Output Terminals</b> .....	<b>18</b>
<b>Sequence of Operation</b> .....	<b>19</b>
<b>Welding Techniques</b> .....	<b>19</b>
<b>Volt-Amp Characteristic Curves</b> .....	<b>20</b>
<b>Duty Cycle</b> .....	<b>20</b>

## **MAINTENANCE**

<b>Service</b> .....	
<b>Internal Cleaning</b> .....	<b>21</b>
<b>External Troubleshooting</b> .....	<b>21</b>
<b>General Troubleshooting</b> .....	<b>21</b>
<b>Internal Troubleshooting</b> .....	<b>21</b>

## **DRAWINGS & PARTS LISTS**

<b>Parts List for 230/460 Final Stick Assembly</b> .....	<b>22</b>
<b>230/460V Final Stick Assembly</b> .....	<b>23</b>
<b>Front Panel Assembly and Parts List</b> .....	<b>24</b>
<b>Rear Panel Assembly and Parts List</b> .....	<b>25</b>
<b>Parts List for Capacitor Chassis Assembly</b> .....	<b>26</b>
<b>230/460V Capacitor Chassis</b> .....	<b>27</b>
<b>230/460V Chassis Plate Assembly and Parts List</b> .....	<b>28</b>
<b>230/460V Inductor Plate Assembly and Parts List</b> .....	<b>29</b>
<b>Schematic PowCon 300SS 230/460V</b> .....	<b>30</b>

## **LIST OF TABLES**

<b>Specifications of PowCon 300SS</b> .....	<b>8</b>
<b>Recommended Fuse Sizes Based on National Electrical Code Requirements</b>	<b>10</b>
<b>Recommended Primary Cable Size Based on National Electric Code Requirements</b> .....	<b>11</b>
<b>Recommended Copper Welding Cable Sizes Based on 60% Duty Cycle and Combined Length of Electrode Ground Cable</b> .....	<b>12</b>
<b>Recommended Power and Range Settings for SMAW DCRP with PowCon 300SS</b>	

## **LIST OF FIGURES**

<b>Electronic Block Diagram of Converter Principle</b> .....	<b>9</b>
<b>Typical SMAW Setup</b> .....	<b>13</b>
<b>Location 1 &amp; 2 Voltage Changeover</b> .....	<b>16</b>
<b>Location 3 Voltage Changeover</b> .....	<b>17</b>

# SAFETY

## ! IMPORTANT !

THIS MANUAL HAS BEEN DESIGNED FOR EXPERIENCED WELDING AND CUTTING EQUIPMENT OPERATORS AND MUST BE READ COMPLETELY BEFORE USING THIS EQUIPMENT. IF YOU LACK EXPERIENCE OR ARE UNFAMILIAR WITH THE PRACTICES AND SAFE OPERATION OF WELDING AND CUTTING EQUIPMENT, PLEASE CONSULT YOUR FOREMAN. DO NOT ATTEMPT TO INSTALL, OPERATE, OR PERFORM MAINTENANCE ON THIS EQUIPMENT UNLESS YOU ARE QUALIFIED AND HAVE READ AND UNDERSTOOD THIS MANUAL. IF IN DOUBT ABOUT INSTALLING OR OPERATING THIS EQUIPMENT, CONTACT YOUR DISTRIBUTOR OR THE CUSTOMER SERVICE DEPARTMENT OF PowCon.

## DEFINITIONS

Throughout this manual, NOTE, CAUTION, WARNING and DANGER are inserted to call attention to particular information. The methods used to identify these highlights and the purpose for which each is used, are as follows:

### NOTE

Operational, procedural, and background information which aids the operator in the use of the machine, helps the service personnel in the performance of maintenance, and prevents damage to the equipment.

### CAUTION

An operational procedure which, if not followed, may cause minor injury to the operator, service personnel and/or bystanders.

### WARNING

An operational procedure which, if not followed, may cause severe injury to the operator, service personnel, or others in the operating area.

### DANGER



An operational procedure which, if not followed, will cause severe injury or even death to the operator, service personnel or bystanders.

## SAFETY INFORMATION

Safety is a combination of good judgement and proper training. Operation and maintenance of any arc welding and cutting equipment involves potential hazards. Individuals who are unfamiliar with cutting and welding equipment, use faulty judgement or lack proper training, may cause injury to themselves and others. Personnel should be alerted to the following potential hazards and the safeguards necessary to avoid possible injury. In addition, before operating this equipment, you should be aware of your employer's safety regulations.

BE SURE TO READ AND FOLLOW ALL AVAILABLE SAFETY REGULATIONS BEFORE USING THIS EQUIPMENT.

## ELECTRIC SHOCK



THE VOLTAGES PRESENT IN THE WELDING AND CUTTING ENVIRONMENT CAN CAUSE SEVERE BURNS TO THE BODY OR FATAL SHOCK. THE SEVERITY OF ELECTRICAL SHOCK IS DETERMINED BY THE PATH AND THE AMOUNT OF CURRENT THROUGH THE BODY.

- A) Install and continue to maintain equipment according to USA Standard C1, National Electric Code.
- B) Never allow live metal parts to touch bare skin or any wet clothing. Use only dry gloves.
- C) When welding or cutting in a damp area, or when standing on metal, make sure you are well insulated by wearing dry gloves, rubber soled shoes, and by standing on a dry board or platform.
- D) Do not use worn or damaged welding or torch cables. Do not overload the cables. Use well maintained equipment.
- E) When not welding/cutting, turn equipment OFF. Accidental grounding can cause overheating and create a fire hazard. Do not coll or loop the cable around parts of the body.

# SAFETY

F) The ground cable should be connected to the workpiece as close to the work area as possible. Grounds connected to building framework or other locations remote to the work area reduce efficiency and increase the potential hazard of electric shock. Avoid the possibility of the cutting current passing through lifting chains, crane cables or other electrical paths.

G) Keep everything dry you might touch, including clothing, the work area, welding gun, torch and welding or cutting machines. Fix water leaks immediately. Do not operate equipment standing in water.

H) Never use a cutting torch or welding gun which is damaged or contains cracks in its housing.

I) Refer to AWS-Z49.1 for grounding recommendations.

## PERSONAL PROTECTION



**SKIN AND EYE BURNS RESULTING FROM BODY EXPOSURE TO ELECTRIC-ARC WELDING AND CUTTING RAYS OR HOT METAL CAN BE MORE SEVERE THAN SUNBURN.**

A) Use a proper face shield fitted with the correct filter (#10 or greater) and cover plates to protect your eyes, face, neck and ears from the sparks and rays of the cutting/welding arc when cutting/welding or observing cutting/welding. Warn bystanders not to watch the arc and not to expose themselves to the cutting/welding arc rays or to hot metal.

B) Wear flameproof gauntlet-type gloves, a heavy long-sleeve shirt, cuffless trousers, high-topped shoes, and a welding helmet or cap (for hair protection) to protect the skin from arc rays and hot sparks or hot metal.

C) Protect other nearby personnel from arc rays and hot sparks with a suitable non-flammable partition.

D) Always wear safety glasses or goggles when in a cutting or welding area. Use safety glasses with side shields or goggles when chipping slag or grinding. Chipped slag is hot and may travel a considerable distance. Bystanders should also wear safety glasses or goggles.

E) Compressed gas cylinders are potentially dangerous, refer to the suppliers for proper handling procedures.

F) Wear ear plugs or other ear protection devices when operating cutting or welding equipment.

## FIRE SAFETY



# SAFETY

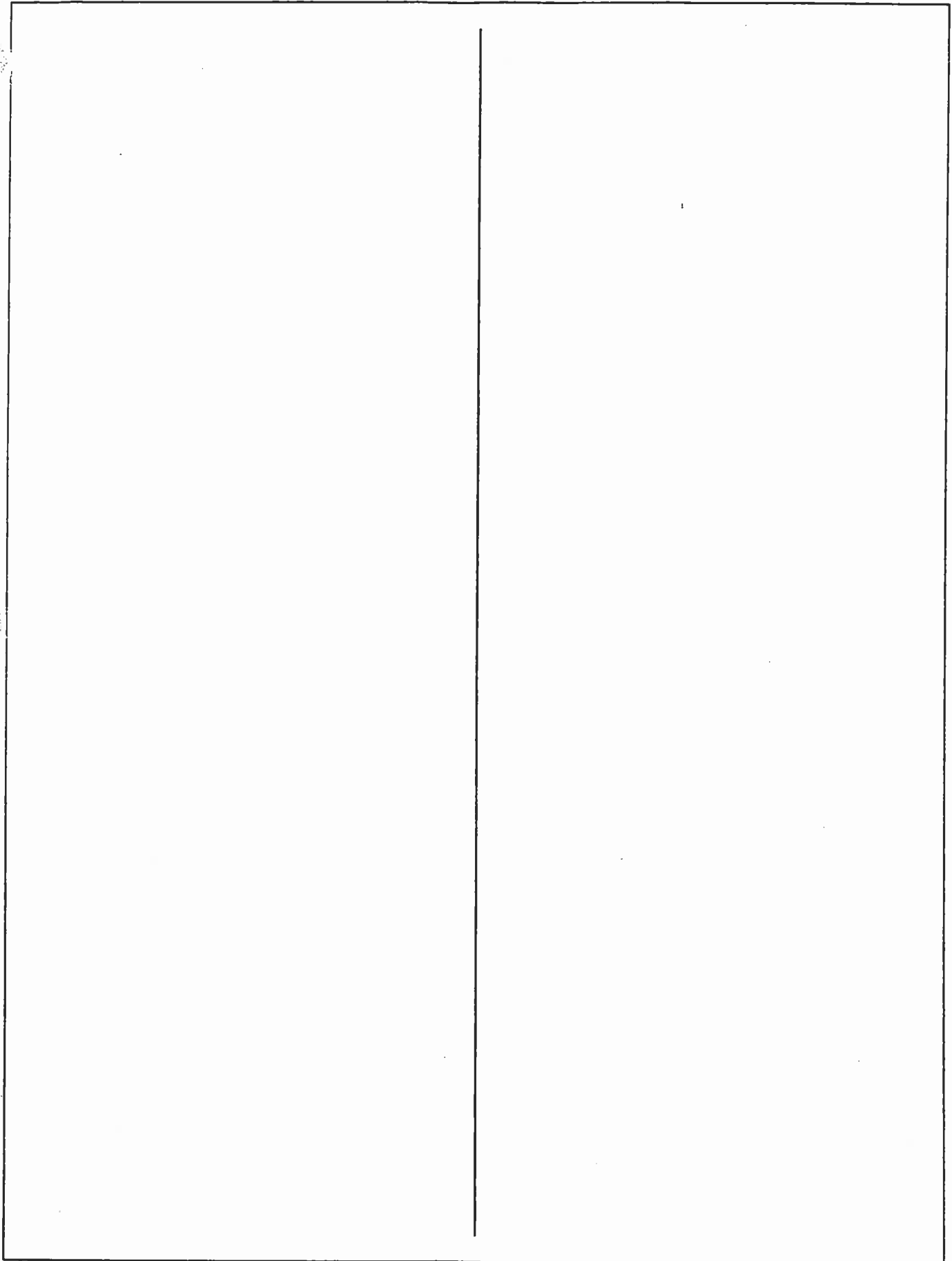

## IMPORTANT!

CE MANUEL A ETE CONCU A L'INTENTION D'OPERATEURS AYANT DE L'EXPERIENCE AVEC DES APPAREILS DE SOUDAGE ET DECOUPAGE. IL DOIT ETRE LU INTEGRALEMENT AVANT L'UTILISATION DE CE MATERIEL. SI VOUS MANQUEZ D'EXPERIENCE ET N'ETES PAS FAMILIARISES AVEC LES METHODES ET LE FONCTIONNEMENT SANS RISQUES DE MATERIEL DE SOUDAGE ET DECOUPAGE, VEUILLEZ CONSULTER VOTRE CONTREMAITRE. N'ESSAYEZ PAS D'INSTALLER, DE FAIRE FONCTIONNER OU D'EFFECTUER L'ENTRETIEN DE CET EQUIPEMENT A MOINS QUE VOUS NE SOYEZ QUALIFIE ET QUE VOUS AYEZ LU ET COMPRIS CE MANUEL. EN CAS DE DOUTE QUANT A L'INSTALLATION ET AU FONCTIONNEMENT DE CET EQUIPEMENT, CONTACTEZ VOTRE DISTRIBUTEUR OU LE DEPARTEMENT SERVICE A LA CLIENTELE DE PowCon.

## DEFINITIONS

Des mots tels que AVIS, ATTENTION, AVERTISSEMENT ET DANGER figurent tout au long de ce manuel pour attirer votre attention sur des informations particulières. Les méthodes utilisées pour les mettre en évidence et le but poursuivi à cet égard sont les suivants:

### AVIS

Information de base concernant le fonctionnement, les procédés qui aident l'opérateur dans l'utilisation de la machine, aide le personnel responsable de la révision à effectuer l'entretien et empêche tout dommage à l'équipement.

### ATTENTION

Un procédé de fonctionnement qui, s'il n'est pas suivi, risque de causer une blessure légère à l'opérateur, au personnel d'entretien et/ou à des observateurs.

### AVERTISSEMENT

Un procédé de fonctionnement qui, s'il n'est pas suivi, risque de causer une blessure grave à l'opérateur, au personnel d'entretien ou à d'autres personnes à proximité.

## DANGER



Un procédé de fonctionnement qui, s'il n'est pas suivi, risque de causer une blessure grave ou même la mort de l'opérateur, du personnel d'entretien ou d'observateurs.

## INFORMATIONS SUR LA SECURITE

La sécurité se base à la fois sur un bon jugement et une formation adéquate. Le fonctionnement et l'entretien de tout équipement destiné au soudage à l'arc et au découpage comporte des risques potentiels. Des personnes qui ne sont pas familiarisées avec l'équipement de découpage et de soudage font des appréciations erronées ou manquent d'une formation adéquate et sont susceptibles de se blesser et de blesser les autres. Le personnel devrait être averti des dangers potentiels énumérés ci-après tout en ayant connaissance des mesures de sécurité nécessaires pour éviter toute blessure éventuelle. En outre, avant d'utiliser cet équipement, vous devriez connaître les règles de sécurité de votre employeur.

VEILLEZ A LIRE ET A SUIVRE TOUTES LES REGLES DE SECURITE A VOTRE DISPOSITION AVANT D'UTILISER CET EQUIPEMENT.

## CHOC ELECTRIQUE



DES TENSIONS PRESENTES DANS LA ZONE DU SOUDAGE ET DU DECOUPAGE SONT SUSCEPTIBLES DE CAUSER DES BRULURES GRAVES SUR LE CORPS OU UN CHOC FATAL. LA GRAVITE DU CHOC ELECTRIQUE EST DETERMINEE PAR LE TRAJET ET LA QUANTITE DE COURANT TRAVERSANT LE CORPS.

A) Installer et poursuivre l'entretien de l'équipement selon "USA Standard C1, National Electric Code." (Norme USA C1).

B) Eviter tout contact de pièces métalliques sous tension avec la peau nue ou un vêtement mouillé. N'utiliser que des gants secs.

C) Lorsque vous procédez à une opération de découpage ou de soudage dans une zone humide, veillez à une isolation adéquate en revêtant des gants secs, des chaussures avec semelles en caoutchouc et en vous plaçant sur une planche ou une plate-forme sèche.

D) N'utilisez pas de câbles de chalumeau usés ou endommagés. Évitez toute surcharge des câbles. N'utilisez que du matériel bien entretenu.

E) Lorsque vous êtes à l'arrêt, éteindre le courant de votre équipement. Une mise à la terre accidentelle est susceptible de causer une surchauffe et un risque d'incendie. Ne pas enrouler ou torsader le câble autour de parties du corps.

F) Veillez à ce que le câble de mise à la terre soit relié à l'instrument de travail le plus près possible de la zone de travail. Les terres reliées à la charpente d'un bâtiment ou à tout autre espace éloigné du lieu de travail présentent une efficacité réduite et augmentent le danger d'un choc électrique. Éviter que tout courant de découpage ne passe à travers des chaînes de levage, des câbles de grue ou d'autres trajets de lignes électriques.

G) Veillez à ce que tout ce que vous touchez soit sec, notamment les vêtements, l'espace de travail, pistolet à souder, chalumeau, machine à découper et à souder. Réparer toute fuite d'eau immédiatement. Ne pas utiliser d'instruments se trouvant dans l'eau.

H) Ne jamais utiliser un chalumeau à couper endommagé ou dont la structure présente des fissures.

I) Reportez-vous à la norme AWS-Z49.1 pour ce qui concerne les recommandations de mise à la terre.

## PROTECTION DES PERSONNES



DES BRULURES A LA PEAU ET AUX YEUX APRES S'ETRE EXPOSE AUX RAYONS DU SOUDAGE ET DECOUPAGE A L'ARC ELECTRIQUE OU AU METAL CHAUD PEUVENT ETRE PLUS GRAVES QU'UN COUP DE SOLEIL.

A) Utilisez un écran protecteur pour le visage avec un filtre correct (no. 8 ou plus élevé) ainsi que des plaques pour protéger les yeux, le visage, le cou et les oreilles contre les étincelles et les rayons du découpage à l'arc, soit pendant que vous procédez au découpage soit pendant que vous observez. Avertissez les observateurs de ne pas regarder l'arc et de ne pas s'exposer aux rayons de découpage à l'arc ou à du métal chaud.

B) Mettez des gants à crispin ininflammables, une chemise à manches longues épaisse, des pantalons sans revers, des chaussures fermées, et une casquette (pour protéger les cheveux) afin de protéger la peau contre les rayons de l'arc, les étincelles ou le métal chauds.

C) Protégez d'autres membres du personnel se trouvant à proximité des rayons de l'arc et des étincelles brûlantes au moyen d'une cloison adéquate ininflammable.

D) Portez toujours des lunettes de sécurité lorsque vous vous trouvez dans une zone de soudage ou découpage. Utilisez des lunettes de sécurité avec écrans latéraux lorsque vous taillez des scories ou lorsque vous broyez. Des scories taillées sont chaudes et risquent de se déplacer sur des distances considérables. Les personnes qui observent doivent également porter des lunettes de sécurité.

E) Des cylindres de gaz comprimé présentent un danger potentiel. Adressez-vous aux fournisseurs pour les procédures de manutention.

F) Portez des boules Quiès ou tout autre système de protection pour les oreilles lorsque vous utilisez du matériel de découpage.



## PROTECTION ANTI-INCENDIES



**DES SCORIES CHAUDES OU DES ETINCELLES PEUVENT CAUSER UN INCENDIE GRAVE AU CONTACT DE SOLIDES, LIQUIDES OU GAZ COMBUSTIBLES.**

A) Eloignez tout matériel combustible à une bonne distance de la zone de découpage, ou bien couvrez complètement ce matériel au moyen d'une couverture ininflammable. Citons parmi les matériaux inflammables: bois, vêtements, sciure de bois, essence, kérosène, peintures, solvants, gaz naturels, acétylène, propane et d'autres articles combustibles similaires.

B) N'effectuez pas de soudage, ou découpage ou tout autre travail à chaud sur des tonneaux, cylindres, réservoirs ou autres récipients avant qu'ils n'aient été complètement nettoyés et ce, afin d'éliminer toute substance dans le récipient susceptible de produire des vapeurs inflammables ou toxiques.

C) Comme protection contre l'incendie, ayez un système d'extinction à portée de la main pour utilisation immédiate.

## VENTILATION



**LES GAZ ET EMANATIONS PROVENANT DE SOUDAGE ET DECOUPAGE, EN PARTICULIER DANS DES ENDROITS FERMES, PEUVENT CAUSER UN MALAISE OU UN DOMMAGE PHYSIQUE S'ILS SONT INHALES PENDANT UNE PERIODE PROLONGEE.**

A) Prévoyez une ventilation adéquate dans la zone de soudage et de découpage au moyen d'une ventilation naturelle ou mécanique. Ne découpez pas des matériaux galvanisés tels que du zinc, plomb, béryllium, ou cadmium à moins qu'une ventilation mécanique positive ne soit en place pour éviter que les émanations et gaz provenant de ces matériaux ne soient inhalés.

B) Ne procédez pas à du découpage à proximité de vapeurs d'hydrocarbure chloré provenant d'opérations de dégraissage ou de pulvérisation. La chaleur des rayons de l'arc pourrait réagir avec les vapeurs des solvants pour former du phosgène, un gaz très toxique, ainsi que d'autres gaz irritants.

C) Si vous ressentez une irritation momentanée aux yeux, au nez ou à la gorge, c'est un signe que la ventilation n'est pas adéquate. Arrêtez votre travail et prenez les mesures nécessaires pour améliorer la ventilation dans la zone de découpage. Ne continuez pas le découpage si le malaise persiste.

D) Utilisez un appareil respiratoire avec approvisionnement en air si la ventilation ne suffit pas à éliminer toutes les émanations et les gaz.

E) Faites attention aux fuites de gaz. Les gaz de découpage contenant de l'argon sont plus denses que l'air et remplaceront celui-ci dans des espaces fermés. Ne placez pas de cylindres de gaz dans des espaces fermés. FERMEZ le gaz à la source lorsqu'il n'est pas utilisé.

F) Reportez-vous à la norme AWS Z49.1 en ce qui concerne les recommandations de ventilation.

## REFERENCES DE SECURITE

Les publications suivantes fournissent des informations supplémentaires concernant des mesures de sécurité importantes pour le soudage:

A) ANSI/ASC Z49.1-1988, American National Standard "Safety in welding and cutting" (Norme nationale américaine "Sécurité en matière de soudage et découpage).

B) Bulletin No. F4-1. "Recommended safe practices for the preparation for Welding and Cutting Containers and Piping that have held Hazardous Substances". (Méthodes pratiques de sécurité recommandées pour la préparation du soudage et découpage de récipients et conduits ayant contenu des substances dangereuses.)

C) OSHA Safety and Health Standards, 29CFR 1910 à obtenir auprès du "United States Department of Labor", Washington, DC 20210. (Normes de Sécurité et Hygiène OSHA 29CFR 1910).

D) NFPA Standard 51B "Fire prevention in Use of Cutting and Welding Processes", à obtenir auprès du "National Fire Protection Association", 470 Atlantic Avenue, Boston, MA 00210. (Mesures de prévention d'incendies utilisées dans les procédés de découpage et soudage).

E) NEMA Standards Publication/No. EW1-1989, Electric Arc Welding Apparatus, approuvé sous la mention ANSI C87.1-1989. A obtenir auprès du "National Electrical Manufacturers Association", 155 E.44th Street, New York, N.Y 10017 (Appareil de soudage à l'arc).

# GENERAL INFORMATION

## DESCRIPTION OF EQUIPMENT

The **PowCon 300SS** is a portable welding power source designed primarily for STICK (SMAW) welding. It is also capable of performing carbon arc gouging, stud welding and scratch-start (TIG) welding. The 300SS can also be paralleled for higher amperage applications.

## SPECIFICATIONS

**PowCon 300SS Welding Power Source:**

- A) Power Input and Output (see Table 1)
- B) Open Circuit Voltage - 80V maximum
- C) Current Range - adjustable from 30 to 375 amps
- D) Weight ..... 70 pounds (31.8 Kg)
- E) Dimensions ..... Height 17" (43 cm),  
..... Width 10" (25 cm),  
..... Depth 19" (48 cm)

- F) The post flow time is factory set at approximately 10 seconds. If a greater time (10 - 20 seconds) is required R19 on the PWB can be adjusted. Consult the factory for the instructions on this adjustment.

### Accessories:

- A) Remote GMAW pulser.
- B) Remote, foot-operated and hand-operated contactor and current control.
- C) Remote control cable extension - 12 ft (3.6M) or 25 ft (7.6M) or 50 ft (15.2M) lengths.
- D) Output cable connectors (DINSE or TWECO).
- E) Relay Kit
- F) Wirefeeders
- G) Carts and Caddles

**TABLE 1**

**SPECIFICATIONS OF PowCon 300SS**

Input	Rated Welding Current Amperes 60% Duty Cycle	Welding Amp. Range	Open Circuit Voltage	Amperes Input at Rated Load Output 50% Duty Cycle			KVA	KW	EFF.	Dim.	Weight		
				230V / 460V	380V	575V					Net	Ship	
Three - Phase	300 amps @ 32V	30-180 100-375	80 max	33.4	16.7	20.8	13.4	13.3	11.6	82.5%	Height: 17" 43 cm  Width: 10" 26 cm	65 lb 29.5 kg	70 lb 31.8kg
Single - Phase	200 amps @ 28V			41	N/A	N/A	N/A	N/A	N/A	N/A			

\* Three input voltage models available - 230/460V, 380V, 575V

## THEORY OF OPERATION

The **PowCon** Welding Power Sources use the frequency converter principle to produce direct current DC power. In contrast to the conventional transformer rectifier, the frequency converter design offers two main advantages: (1) lower weight and (2) smaller size.

For the **PowCon**, the input alternating current (AC) primary power is passed through a circuit breaker to a 6 pulse full wave bridge rectifier, where the input is transformed to DC power. The DC current output of the rectifier is fed to an inverter of series capacitor switching type. Using SCR's (thyristors), the DC current is switched alternately ON and OFF. The action of charging and discharging the SCR's creates a new alternating current (AC). The frequency of the firing of the SCR's varies from 400 Hz to 6,000 Hz, dependent upon the output demand, i.e., the greater

the output power required, the higher the frequency. The output power is determined by the weld power dial setting range.

The new alternating current, with its higher frequency provided by the switching devices (SCR's), is fed into the main transformer. One advantage of higher frequency alternating current is a significantly reduced transformer size. The **PowCon** main transformer weighs 12 pounds, versus approximately 200 pounds used in the conventional transformer rectifier. The transformer takes the higher voltage of the switching SCR's and transforms it to the welding voltage range.

The final step in the production of weld current is the AC output of the transformer which is rectified by diodes into direct current (DC) for welding. The whole sequence of operations from the primary (AC) input to the weld output (DC), is regulated by the main PC board through control logic feedback.

# GENERAL INFORMATION

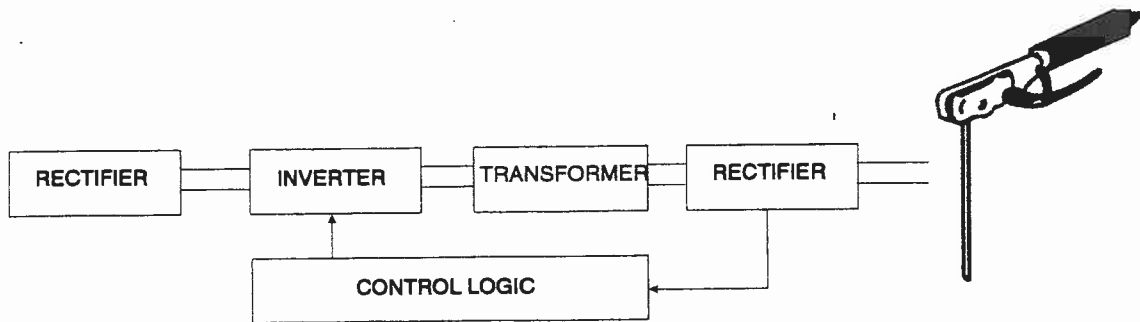

Figure 1, Electronic Block Diagram of Converter Principle

## SPECIAL SAFEGUARDS FOR USE WITH THE PowCon 300

Individuals using this equipment should give the following safeguards their special attention.

- A) Install the PowCon welding power source in with OSHA and National Electrical Code applicable standards.
- B) Locate the unit so that air flow into the front and out of the back is not obstructed.
- C) Provide access to all controls on both the front and back panel for operator manipulation.
- D) Never drag, pull or lift the unit by either the primary or secondary electrical cable.
- E) Never place the unit in a location where the unit's weight cannot be supported, especially when the unit is above level.
- F) Do not allow the unit, or its input and output cables, to impede or block foot traffic.
- G) Move and lift the unit in accordance with OSHA job site standards.
- H) Servicing of the unit should be done only by personnel factory trained by PowCon.
- I) When servicing the unit, the first operation, once the case is removed from the source of primary input, is to discharge the capacitors.
- J) Periodically blow or vacuum out dirt build-up in the unit.
- K) Do not operate unit if the circuit breaker must be forced or repeatedly held in the ON position.
- L) Never lift or move the unit when the circuit breaker is ON.
- M) Follow the recommendations for fuse and cable sizing when connecting the unit.
- N) Always turn the unit OFF when it is not in use.
- O) Primary quick disconnects, etc., must be suitably rated for current demand at primary voltage.
- P) Read entire manual prior to performing operations using power source.

# INSTALLATION

## UNPACKING NEW EQUIPMENT (Receiving and Handling)

Remove the PowCon Welding Power Source from its shipping carton and inspect for any possible damage that might have occurred during shipping. Make sure that all items on the packing list are accounted for and identified. One copy of the PowCon 300 Operation Manual is packed with each PowCon 300 unit.

Any claims for loss or damage that may have occurred in transit must be filed by the PURCHASER with the CARRIER. Copies of the bill of lading and freight bill will be furnished by the carrier on request, if the need to file a claim arises. When requesting information concerning this equipment, it is essential that model description, serial number and/or part number of the equipment be supplied.

### NOTE

TO ASSURE A VALID WARRANTY, YOU MUST COMPLETE AND RETURN THE WARRANTY CARD (ENCLOSED WITH ALL PRODUCTS) WITHIN 10 DAYS OF THE PURCHASE DATE.

## U.L. REQUIREMENTS

### READ BEFORE CONNECTING POWER

Listing by Underwriter's Laboratories, Inc. covers this welder only. Listing does not cover an evaluation of the suitability of the attachment plug cap which is provided and installed in the field.

Only a qualified electrician should perform the installation of the PowCon unit to primary power. All installations of this type must conform to the regulations of the National Electrical Code and any other local codes which may be applicable.

These regulations include, but are not limited to, using the proper ampacity primary cord, properly phasing the connection to three phase power with respect to the ground line (green), and providing the proper strain relief between the primary cable and the field connection box or wiring box.

When an attachment plug cap is installed, it must be U.L. Listed, complying with paragraph 9.10 of U.L. 551, Transformer-Type Arc Welding Machines. A cap such as the NEMA type pin configuration with typical manufacturer's code/serial number (1) Hubbell Cat# 9451/NEMA 14.50P for 208V/10 and 230V/30, and (2) Hubbell Cat# 2431/NEMA L16.20P for 460V/30. Make sure that the chosen pin configuration is appropriate for the primary voltage you are using.

The green lead on the primary cable is the ground lead. This must be connected to the indicated terminal on the plug cap. The remaining three phases may be connected in any order to the other terminals on the plug. In the case of a screw connection, care should be taken to ensure that the stranded leads on the primary cable are properly seated before tightening. There should be no loose strands protruding from the sides or back of the terminal after tightening.

After connecting the leads, perform the attachment of the plug casing and the strain relief. The strain relief should grip at least

1/2" of the primary cable's outer jacket. Under no circumstances should the strain relief be connected only to the individual leads of the primary cable. This will result in a shortened cable life and in an unsatisfactory strain relief.

Before connecting the unit to the primary power, check to see that the unit is wired for the proper voltage. Refer to Procedure for Input Voltage Change-Over in this manual for the proper voltage change-over procedure.

## EQUIPMENT INSTALLATION (Input Power Requirements)

The PowCon 300 is manufactured for use on 230 or 460 volt, 50/60 hertz, three phase power and 230 volt, 50/60 hertz, single phase power.

The PowCon 300 comes from the factory wired for 440 to 480 VAC input. To perform a voltage change-over, be sure to review and understand the voltage change-over procedure. Also, understand the purpose and application of the "230" label supplied with the unit.

It's not necessary to check the phasing of the power lines. The PowCon 300 will work properly on any phase sequence.



### DANGER

AN ELECTRICAL GROUND MUST ALWAYS BE PROVIDED TO CONNECT TO THE GREEN WIRE ON THE FACTORY INSTALLED PRIMARY CABLE.

### FUSE SIZE

The PowCon 300 is equipped with a 12 foot (3.6 M) power cord attached. The power cord size is 10 AWG for 230 volt and 460 volt operation. For proper fuse see Table below.

TABLE 2

### RECOMMENDED FUSE SIZES BASED ON NATIONAL ELECTRICAL CODE REQUIREMENTS

	Max	Recommended
230V, 30	46A	60A
460V, 30	23A	30A
208V, 230V, 10	41A	

\*Maximum current demand is based on an output of 35.2 VDC and 375A for 3 phase input. For single phase input maximum current demand is based on output of 28 VDC and 200A.

# INSTALLATION

## PRIMARY WIRE SIZE

Additional lengths of primary cable are to be considered extension cords to the factory supplied power cord. To maintain the necessary degree of safety, the use of suitably rated U.L. recognized male/female connector plugs in required (see recommended fuse capacity shown in Table below.) Extension primary cord lengths must be of the same grade wire for their entire length, as shown in Table.

**TABLE 3**

### RECOMMENDED PRIMARY CABLE SIZE BASED ON NATIONAL ELECTRICAL CODE REQUIREMENTS

Cable Length	Required Primary Cable Size
250 feet or less (176M)	10 AWG
250 feet to 400 feet (122M)	8 AWG
400 feet to 650 feet (198M)	6 AWG

\*The entire extension cable length must be made of the required cable size. For example, a 500 foot extension would be made of 6 AWG cable with appropriate U.L. recognized plugs to connect to the factory provided 12 foot primary.



## DANGER

NEVER CONNECT OR DISCONNECT THE PRIMARY UNLESS THE UNIT IS TURNED OFF AT THE CIRCUIT BREAKER LOCATED ON THE REAR PANEL. THE PRIMARY SUPPLY LINE SHOULD ALWAYS BE SWITCHED OFF DURING INSTALLATION.

A GROUND MUST ALWAYS BE PROVIDED TO CONNECT TO THE GREEN WIRE ON THE FACTORY INSTALLED PRIMARY.

## SINGLE PHASE INSTALLATION

Perform the following steps on the factory equipped primary:

- A) Check if unit is internally wired for required primary voltage (see voltage change-over procedure). The current voltage setting is indicated on the data label on the top of the unit.
- B) Connect green wire to ground.
- C) Connect both white and black wires to "HOT" legs.
- D) Electrically isolate red wire.

## NOTE

DO NOT CONNECT THE RED OR GREEN WIRE TO A NEUTRAL.

## THREE PHASE INSTALLATION

Perform the following steps on the factory equipped primary:

- A) Check if unit is internally wired for required primary voltage (see voltage change-over procedure.) The current voltage setting is indicated on the data label on the top of the unit.
- B) Connect green wire to ground.
- C) Connect white, black and red wires to "HOT" legs.

## ENGINE DRIVEN GENERATOR USE

Failure to take special precautions with the PowCon Welding Power Sources and engine driven generators will result in damage to equipment. The following special startup procedure MUST be followed to prevent damage to both the unit and the generator.

## CAUTION

NEVER START UP THE GENERATOR WITH THE CIRCUIT BREAKER ON THE PowCon UNIT IN THE UP/ON POSITION. THE PowCon UNIT MAY BE SWITCHED ON AT THE CIRCUIT BREAKER ONLY AFTER THE GENERATOR IS STARTED AND RUNNING STEADY (AT LEAST TEN SECONDS).

Perform the following steps on the factory equipped primary:

- A) Check if unit is internally wired for required primary voltage (see voltage change-over procedure.)
- B) Connect green wire to ground.
- C) Connect either single phase or three phase installation as required.

# INSTALLATION

## LOCATION OF EQUIPMENT (Service Operating Conditions)

NEMA Standard EW1-2.02 approved as ANSI C87.1-1976 outlines both usual and unusual service conditions for a welding power source. The PowCon 300 series of welding power sources have been designed and manufactured to meet the usual service conditions as well as conform to the other NEMA standards. If an unusual service condition is required, PowCon should be consulted.

The small size and unique design of the PowCon 300 series of welding power sources requires the operator be aware of certain safeguards regarding the proper procedure for movement and placement of the unit. Good judgement and compliance with your particular job site safety requirements are essential. The following safeguards are recommended for the movement and placement of the unit.

## COOLING

Locate the PowCon Welding Power Source so that air flow into the front and out of the back is not obstructed. Avoid placing the unit where dust or grinding particles will be directed in the unit.

## ACCESS

Locate the PowCon Welding Power Source where there is room for the operator to manipulate controls or change the connections on either the front or back panel. Avoid placing the unit in a hallway or other area where foot traffic might be impeded.

## LIFTING

In lifting and carrying the unit, it is recommended that two people be used. The unit is designed to be lifted using a suitably rated and inspected choker (made of rope or nylon) run through both handles. Refer to the applicable OSHA standards or contact PowCon for any questions regarding the lifting of this unit.

## SECURITY

Locate the unit where it can be secured to a platform, deck or other structure which is capable of safely supporting the unit and any other potential load.

## WARNING

DO NOT ALLOW THE UNIT TO REMAIN OPERATING WHEN LIFTING OR MOVING IT.

DO NOT DRAG OR LIFT THE UNIT BY PRIMARY OR SECONDARY CABLE.



## DANGER

EXERCISE CARE IN THE HANDLING OF PRIMARY AND SECONDARY CABLE TO AVOID WEARING OUT OR LOSS OF ELECTRICAL INSULATION.

DO NOT LIFT THE UNIT UNLESS ALL 10 FLANGE SCREWS AND NUTS HOLDING THE TOP AND BOTTOM CASES ARE TIGHT.

ANY TIME THE PowCon IS PLACED ABOVE GROUND LEVEL, THE POTENTIAL HAZARD OF FALLING EXISTS.

## OUTPUT CONNECTIONS

### WELDING CABLE

Run electrode and ground cables of the appropriate size as shown in Table below. To avoid excessive heat losses during welding, all output connections, lugs and cables should be secure and well insulated. Failure to use proper cable sizes contributes to lost efficiency of the power source and excessive consumption of electrical power.

The electrode and work leads have to be assembled using customer supplied welding cable and cable connectors. After the cables are assembled, connect the electrode lead to the negative (-) jack and the work lead to the positive (+) jack for straight polarity operation. For reverse polarity operation, the electrode lead is connected to the positive (+) jack and the work lead is connected to the negative (-) jack.

## NOTE

LOCATE THE PowCon UNIT SO THAT THE AIR FLOW INTO THE FRONT AND OUT OF THE BACK OF THE UNIT IS NOT OBSTRUCTED.

TABLE 4

RECOMMENDED COPPER WELDING CABLE SIZES BASED ON 60% DUTY CYCLE AND COMBINED LENGTH OF ELECTRODE GROUND CABLE\*

0'-50'	15.2M	1/0
Up to 100'	30.5M	1/0
100'-150'	30.5M-47.7M	1/0
150'-200'	45.7M-61M	2/0
200'-250'	61M-76.2M	3/0

\*Use of aluminum cable requires increase by two AWG sizes over recommended copper cable size. Recommended cable sizes for other duty cycles and output currents can be found in Volume 2, WELDING HANDBOOK, 7th Edition, published by the American Welding Society.

# INSTALLATION

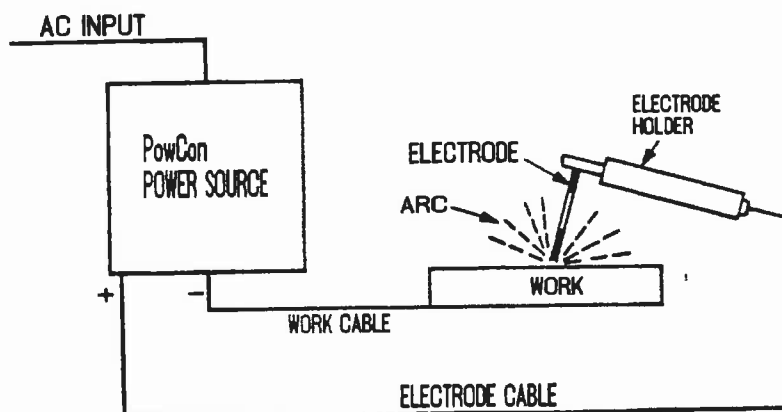

Figure 2, Typical SMAW Setup

## REMOTE CURRENT AND CONTACTOR CONTROL CONNECTIONS

Both the remote control devices (hand and foot) come with a 14-pin connector plug which connects to the remote terminal on the rear panel of the PowCon unit. The remote control devices come with a pre-wired plug and 12 1/2 feet (3.8 M) of cable. When a remote control device is plugged into the rear panel receptacle, certain front panel controls are overridden by the remote device.

To connect the remote control device, insert the 14-pin plug from the control cable of the device fully into the receptacle on the rear panel. Ensure that the plug keyways align with the receptacle keys. Rotate the plug threaded collar clockwise as far as possible into the receptacle threaded body to secure the plug in the receptacle.

## PROCEDURE FOR INPUT VOLTAGE CHANGE-OVER

There are three (3) voltage change-over locations and all three must be connected for the same primary voltage. The three voltage change-overs are located inside the unit and are as follows:

- 1) Working capacitor board (right front side of unit, see Figure 4).
- 2) Copper buss bars for fan motor (left rear side of unit, see Figure 5).
- 3) Copper buss bars for main transformer (front of unit, see Figure 4).

## NOTE

READ ENTIRE PROCEDURE PRIOR TO PERFORMANCE OF VOLTAGE CHANGE-OVER.



## DANGER

IN ORDER TO AVOID AN ELECTRICAL SHOCK, THE UNIT MUST BE TURNED OFF AND DISCONNECTED FROM THE INPUT CIRCUIT PRIOR TO PERFORMING THE VOLTAGE CHANGE-OVER PROCEDURE.

A) Remove the top case from the bottom case as follows:

- 1) Unfasten and remove the 10 bolts and nuts holding the case together.
- 2) Grab handles firmly and gently lift top case with a prying movement.

B) Perform capacitor high voltage bleeding procedure before carrying out voltage changeover as noted in Bleeder Resistor Assembly section.

## WARNING

THE CAPACITORS IN THE PowCon WELDING POWER SOURCE ARE CHARGED WITH HIGH VOLTAGE. THE CAPACITORS WILL DISCHARGE OVER A LONG PERIOD OF TIME UNDER NORMAL SHUTDOWN PROCEDURES. HOWEVER, IN ORDER TO AVOID AN ELECTRICAL SHOCK WHEN THE CASE IS REMOVED, THE CAPACITORS MUST BE DISCHARGED BY THE USE OF A BLEEDER RESISTOR ASSEMBLY.

C) Identify the voltage change-over instruction labels for the copper buss bars and working capacitor board located as shown in Figures 5 and 6.



# INSTALLATION

## LOCATION 1: WORKING CAPACITOR FILTER BOARD CHANGE-OVER

A) Locate the working capacitor PC board as shown in Figure 5.

B) Locate the copper buss bars located near the top of this PC board.

### NOTE

THE COPPER BUSS BARS WHEN IN THE VERTICAL POSITION ARE FOR 230 VAC INPUT, WHILE THE HORIZONTAL POSITION IS FOR 460 VAC INPUT.

C) Perform the required change-over of the copper buss bars for the input voltage.

### NOTE

FOR 230 VAC INPUT THE 3 COPPER BUSS BARS ARE USED IN 3 DIFFERENT LOCATIONS ON THE BOARD, WHILE 460 VAC HAS 2 DIFFERENT LOCATIONS WITH ONE USING DOUBLE COPPER BUSS BARS.

## LOCATION 2: MAIN TRANSFORMER CHANGE-OVER

A) Locate the instruction label for the copper buss bars shown in Location 2 of Figure 4.

B) To gain access to the buss bars for the main transformer located near the front panel, perform the following:

1) Unfasten holding screw on knob of range switch.

2) Remove holding screw and range switch knob.

3) Unfasten and remove two retaining screws for the range switch.

4) Remove range switch from front panel assembly and brace out of the access to buss bar.

5) Gently lift front panel assembly out of bottom case taking care not to damage any connections.

6) Prop front panel assembly up and out of the way to gain access to buss bar.

C) Read the instruction label before performing the required operation on the copper buss bars.

### NOTE

NEVER CHANGE THE WIRING TO THE TERMINALS CONNECTED TO THE BUSS BARS.

D) Reconnect range switch to front panel assembly and reinstall front panel assembly.

## LOCATION 3: FAN TRANSFORMER CHANGE-OVER

A) Locate and read the instruction label for the copper buss bars shown in Location 3 of Figure 5.

B) Perform the required operation on the copper buss bars for the proper primary voltage.

### NOTE

NEVER CHANGE THE WIRING TO THE TERMINALS CONNECTED TO THE BUSS BARS.

C) Recheck all three input voltage change-over buss bar connections to ensure all three are rated for the same input primary voltage.

D) Reinstall the top case to the bottom as follows:

1) Check for loose wires and potential pinch points.

2) Replace top case, paying careful attention to front and back panel assemblies fitting into grooves of top case.

3) Make sure both top and bottom cases fit snug with all 10 holes aligned.

4) Insert bolts in 10 holes of case, thread nuts on bolts and tighten firmly.

E) Check for correct input voltage of primary source and ensure the fuse and plug are UL approved for the rated primary load.

## BLEEDER RESISTOR ASSEMBLY CONSTRUCTION

This assembly must consist of the following components to be considered acceptable for capacitor bleed-off:

**RESISTOR** : Minimum requirements - 50 watts, 5 ohm.

**CONDUCTOR**: #16 AWG 600 VDC insulation rating.

**CLIPS**: #16 AWG 600 VDC insulation rating.

All connections must be hard wired (soldered). Conductors should be approximately three (3) inches in length.

Entire resistor body and soldered connections to resistor must be encapsulated with 600 VDC rated "heat shrink" insulation.

A discharge resistor assembly is available from PowCon (P/N 250040-001). Contact your local distributor or the factory if you wish to obtain it.

# INSTALLATION

## USE

Once an acceptable discharge device (as described in the previous section) is available, perform the following:

### NOTE

READ ENTIRE PROCEDURE PRIOR TO PERFORMING VOLTAGE BLEEDING PROCEDURE.

DO NOT ATTEMPT TO PERFORM THIS PROCEDURE WITHOUT THE POWER SOURCE BEING TURNED OFF AND DISCONNECTED FROM THE PRIMARY INPUT.

A) Turn range switch to highest range.

## CAUTION

FAILURE TO TURN RANGE SWITCH TO HIGHEST RANGE WILL PREVENT DISCHARGE OF ALL THE CAPACITORS.

B) Locate the C.F. assembly inside the unit as shown in Figure 6. The C.F. assembly can be identified by two aluminum heatsinks which contain three diodes each.

C) Connect one end of the bleeder resistor assembly to one of the heatsinks and attach the other end of the bleeder assembly to the other heatsink. This action will bleed the capacitors.

### NOTE

A SPARK DISCHARGE MAY BE NOTICED.

D) Leave the bleeder resistor assembly connected for at least 10 seconds.

E) Remove the bleeder resistor assembly from the unit and continue with the voltage change-over.

## WARNING

DO NOT ATTEMPT TO DISCHARGE THIS POWER SOURCE BY ANY OTHER MEANS THAN THAT DESCRIBED ABOVE.

# INSTALLATION

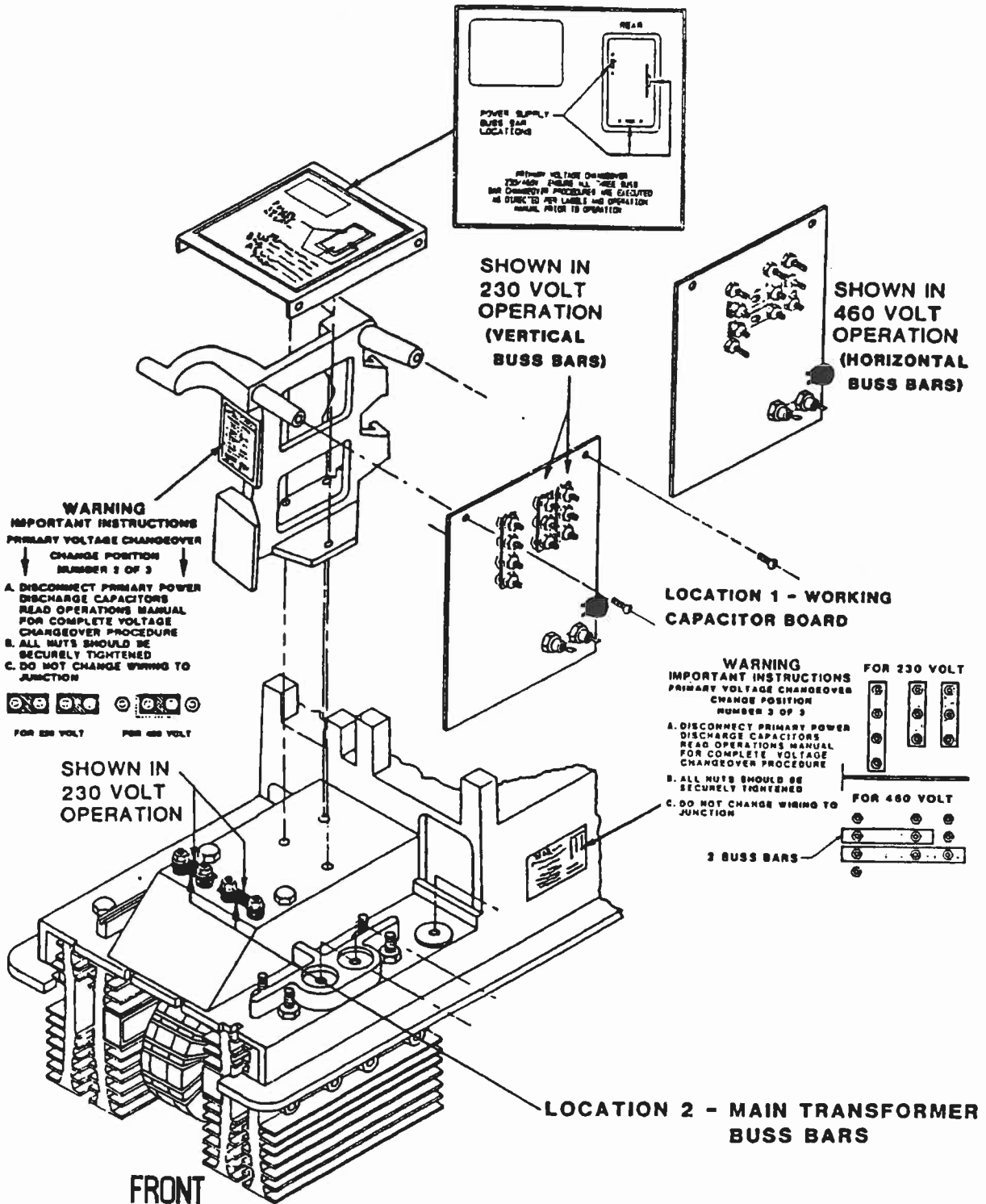

Figure 3, Location 1 and 2 Voltage Changeover

# INSTALLATION

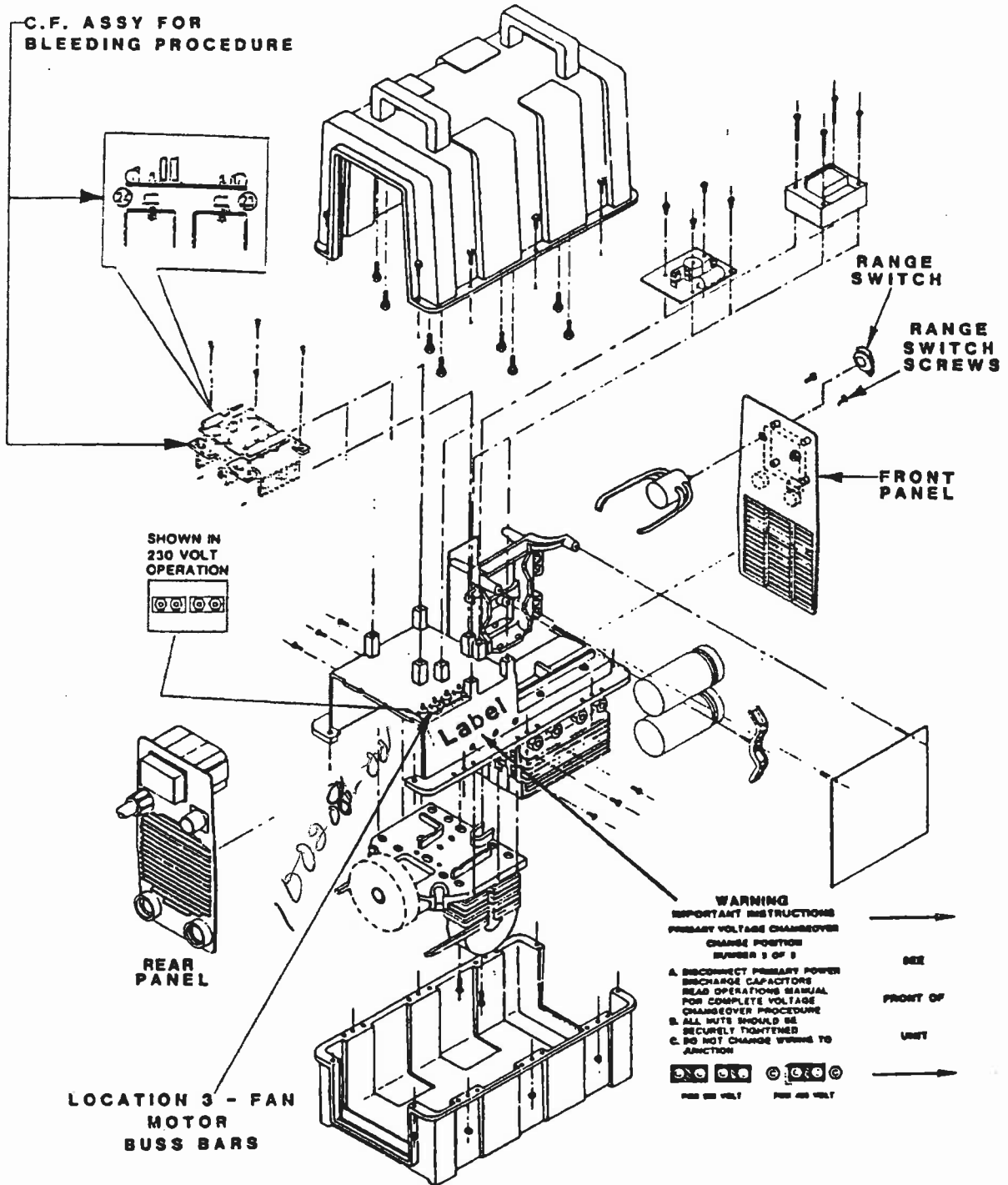

Figure 4, Location 3 Voltage Changeover

# OPERATION

## FUNCTION OF OPERATING CONTROLS AND CONNECTIONS

### 1. Circuit Breaker

The circuit breaker acts as a switch to turn the incoming primary power on and off and also protects the semiconductors in the power source in case of fault in the control circuits.

### WARNING

IN ORDER TO AVOID AN ELECTRICAL SHOCK, POTENTIAL FIRE OR EQUIPMENT MALFUNCTION, THE CIRCUIT BREAKER MUST NEVER BE FORCIBLY HELD CLOSED IN THE ON POSITION.

ONCE THE CIRCUIT BREAKER IS TURNED ON, DC VOLTAGE IS PRESENT AT THE OUTPUT OF THIS POWER SOURCE. THIS MEANS THAT THE ELECTRODE IS LIVE, PRESENTING A LETHAL SHOCK HAZARD.

### 2. Indicator Lamp

Indicates that the circuit breaker is closed and primary power is being supplied to the unit. (This light verifies power on two phases only.)

### 3. Range Switch

Used to select between a high (100 - 375 amp) range and a low (30 - 180 amp) range.

### NOTE

IN ORDER TO PREVENT EQUIPMENT MALFUNCTION, DO NOT SWITCH RANGE WHEN UNIT IS UNDER LOAD.

### 4. Weld Power Control Dial

Adjusts the output of the unit. It is graduated in 10% increments and adjusts from a minimum 30 amps @ 20V with three phase input.

### 5. Remote Control

Connection for remote current control device. When connected, control of the welding power is automatically switched to remote device. The indicator lamp remains on when the remote is connected and the circuit breaker ON.

### 6. Primary Control

Unit comes from factory with 12 feet (3.6 m) of primary lead connected to the circuit breaker through the strain relief. See Installation Section for recommended cable size and fuse requirements.

### 7. Output Terminals

Quick connect female output receptacle with polarity as marked. User must supply cable and male connect plugs. See Installation Section for recommended cable size.

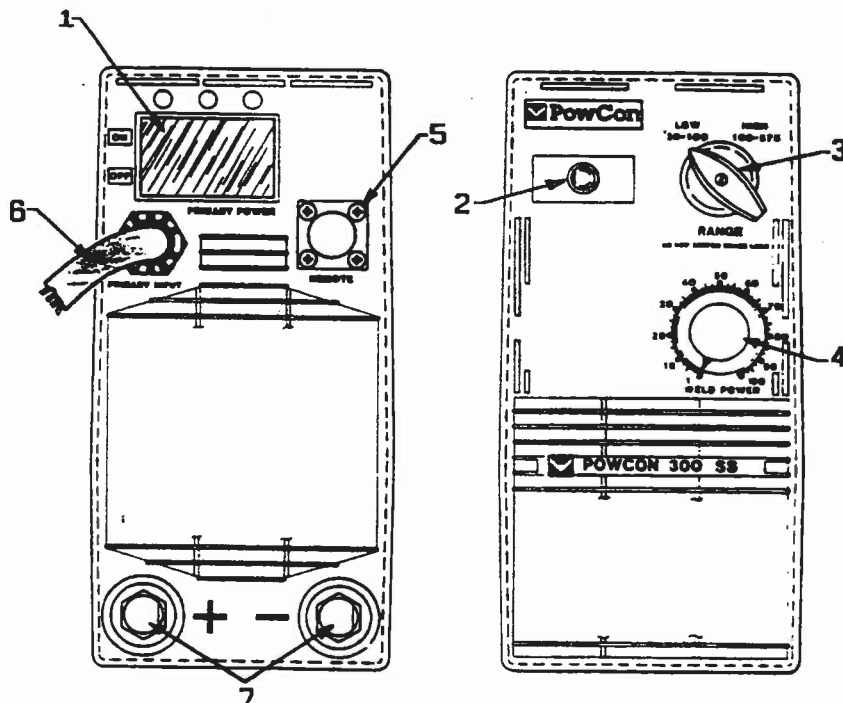

Figure 5, Front and Back Panel Controls and Connection Locations

# OPERATION

## SEQUENCE OF OPERATION

A. Inspect the unit to make sure it is set up properly according to the equipment installation section.

B. Adjust the weld power control to the desired power level needed for you application.

C. Lift the handle of the automatic circuit breaker to its "UP" position. At this time the pilot light will come on and the fan will start. A "ticking" sound will be heard (if the machine is not under load.) This indicates that the rectifier is coming on about once per second for a very short time to provide the open circuit voltage.

The open circuit voltage displayed depends upon the process mode selected. The approximate open circuit voltage displayed under each condition are shown in Table 5.

## NOTE

WHEN EITHER A FOOT OR HAND OPERATED REMOTE DEVICE IS CONNECTED TO THE POWER SOURCE, THE "TICKING" SOUND WILL NOT OCCUR. THE TICKING WILL ONLY OCCUR WHEN THE CONTACTOR IS ENGAGED BY THE REMOTE DEVICE. THE INDICATOR LAMP AND FAN, HOWEVER, WILL REMAIN ON WHILE A REMOTE DEVICE IS INSTALLED.

D. Proceed with your chosen weld program.

E. After welding has been completed, allow the fan in the unit to run for a few minutes to remove the heat form the power source prior to turning the unit off.

## WELDING TECHNIQUES

Welding techniques vary as a function of both the individual performing the operation and the code requirements of the applicable welding procedure. Laboratory tests and industrial users have demonstrated the successful use of the PowCon with a variety of electrode types and diameters. Some typical electrodes and recommended machine settings are shown in Table 5.

The PowCon 300SS has a hot start circuit to aid the welder in striking an arc. The hot start automatically provides a short duration current pulse when the arc is initiated.

**TABLE 5**

**RECOMMENDED POWER AND RANGE SETTINGS FOR SMAW DCRP WITH PowCon 300SS \***

Electrode Diameter	Electrode Type				
	E6010	E6011	E6013	E7018	E309-16
3/32" / 2.38mm	R1, 28	R1, 22		R1, 25	R1, 15
1/8" / 3.17mm	R1, 32 R2, 15	R1, 32	R1, 32	R1, 35	R1, 28
5/32" / 3.96mm	R2, 25	R2, 22	R1, 35	R2, 25	R2, 20
3/16" / 4.76mm	R1, 40 R2, 25				R2, 30

\* These suggested power and range settings represent the manufacturer's best estimate and are intended as guidelines for the user of the PowCon 300SS.

# OPERATION

## VOLT-AMPERE CHARACTERISTIC CURVES

The volt-ampere curves for the PowCon 300SS are shown in Figures 7 and 8. A characteristic curve for each 10 percent increment in power was generated using purely resistive load banks. Curves for other power settings would fall among those curves shown. The characteristic volt-ampere curves show the relationship between load voltage and output current. In the actual welding operation, load voltage is determined by arc length. The volt-ampere curves can be used to determine a power setting which is capable of providing a desired output.

## DUTY CYCLE

The duty cycle of a welding power source is a measure of the capacity of the unit. The PowCon 300 has a duty cycle based on a 10 minute time period. The duty cycle is the percent of that time period the unit can produce the specified output.

The PowCon 300 can operate for 6 minutes out of a 10 minute period at an output of 300 amperes and 32 volts. To assure the safe operation of the unit the remaining 4 minutes must be spent idling to permit proper cooling. The duty cycle at this output is 60%.

Lowering the output current allows increases in the duty cycle. Thus the 100% duty cycle (weld output continuous) is 250 amperes and 30 volts.

## NOTE

FAILURE TO ALLOW UNIT TO IDLE FOR REQUIRED PERIOD OF DUTY CYCLE WILL ACTIVATE THERMAL OVERLOAD DEVICES. IF THESE DEVICES ARE ACTIVATED, UNIT WILL SHUT DOWN UNTIL COMPONENTS ARE NATURALLY COOLED.

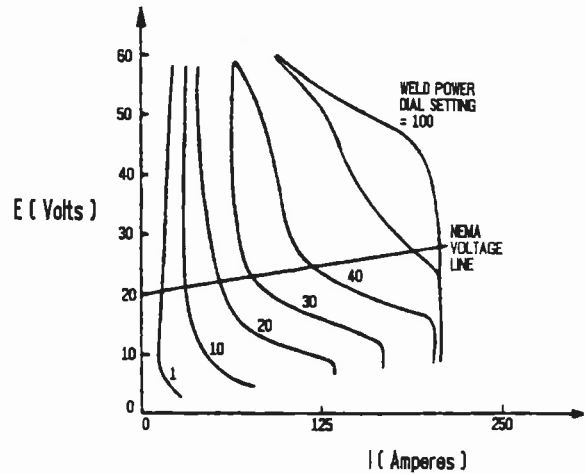

Figure 6, Volt/Amp Characteristic Curves for Range 1

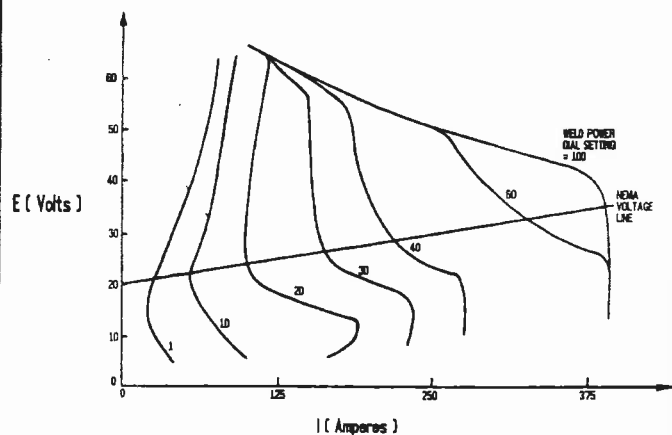

Figure 7, Volt/Amp Characteristic Curves for Range 2

# MAINTENANCE

## SERVICE

Unauthorized service to this unit by anyone other than a PowCon trained and authorized technician will void the limited warranty.

## INTERNAL CLEANING

The use of a PowCon unit in an environment containing airborne dust and dirt requires occasional blowing out or vacuuming of the unit. The frequency of the cleaning operation should be done dependant upon the severity of the environment. Use only clean, dry air or a vacuum suction to clean the unit. Do not open the case; just direct cleaning through the vents while the unit is turned off and disconnected from the primary power source.

## EXTERNAL TROUBLESHOOTING

If the PowCon power source malfunctions, this Troubleshooting Guide will be helpful in locating the problem. This guide covers only malfunctions that can be located and corrected without opening the unit.

- A) Before doing anything else, make sure that the unit is connected to the correct voltage and that all three legs of the three phase power are connected.
- B) Make sure the unit is properly grounded.

- C) The circuit breaker on the rear panel is intended to trip in the event of a fault or component failure in the unit. It does not trip if the unit overheats; the control circuit automatically turns the output off until it cools down.

If the circuit breaker trips it is probable that a fault has occurred. It may be reset ONCE to see if it was a momentary fault.

## NOTE

REPEATED RESETTING OF THE CIRCUIT BREAKER ONLY INCREASES THE CHANCE OF CAUSING ADDITIONAL FAILURES TO THE UNIT.

- D) With no load connected, turn the unit on and switch between all the output ranges. A "ticking" sound should be heard.

## GENERAL TROUBLESHOOTING

Trouble	Possible Cause	Remedy
Welding current too low for power setting.	Phase missing primary power.	Check primary connections.
Welding current too high or too low when remote control is used.	Bad remote control assembly.	Replace.
Unit shuts down while welding. Fan still rotates and ready light working.	Unit overheated due to: a. Running too high amperage. b. Improper cooling of unit.	Wait 10 minutes. Reduce the welding current and duty cycle. Make sure the air vents are not obstructed.

## INTERNAL TROUBLESHOOTING

An input voltage change-over is the only internal service that can be performed by other than a PowCon trained and authorized technician. The input voltage change-over procedure is detailed in in this manual. No other reason exists for unauthorized personnel opening the case of the unit.



## DANGER

BEFORE PERFORMING INPUT VOLTAGE CHANGE-OVER, AN UNDERSTANDING OF THE PRODECURE IS REQUIRED. THE CAPACITORS IN THIS UNIT CAN HOLD A DANGEROUS CHARGE EVEN WHEN THE PRIMARY POWER IS DISCONNECTED. TO DISCHARGE THESE CAPACITORS, USE A BLEEDER TYPE RESISTOR ASSEMBLY AS DESCRIBED ON PAGE 14 FOR INPUT VOLTAGE CHANGE-OVER.



# DRAWINGS & PARTS LIST

Effective following Serial Number SS 2013 TH

## Parts List for Figure 8, 230/460V Final Stick Assembly

Item No.	Qty	Part Number	Description	Ref. Des.
1	1	250018-001	Case, Top Kit	
2	1	100006-001	Case, Bottom	
3	1	100199-01	Capacitor Filter PCB	CF
4	1	<del>101036-001</del> 101538-005T	Control Board	
7	1	100148-001	Assembly, Capacitor Bracket w/PTC	RT3
8	2	900000-001	Capacitor, Input	C1, C2
9	4	970025-506	Screw, PanHead, Supadrive, Self Locking	
10	10	970006-614	Screw, Hex Flanged, 1/4 - 20 X 1 10 - 32 X 1/2	
14	6	970011-506	Screw, FLH, Supadrive, Locking, 10 - 32 X 1/2	
15	10	972001-006	Nut, FlangedHex, Self Locking	
18	1	920000-002	Range Switch SS and SM	S1
21	2	250017-001	Handle Kit	
22	8	970029-605	Scr, Poly-Full-Body, Hex Washer Head, #14 - 7 X 5/8	
23	3	912000-001	Diode, (Anode to Stud)	CR 4 - 6
24	3	912000-002	Diode, (Cathode to Stud)	CR 1 - 3
25	1	100093-001	Data Tag	
28	2	100151-001	Buss Bar	

*100208-001 HEX STD*

# DRAWINGS & PARTS LIST

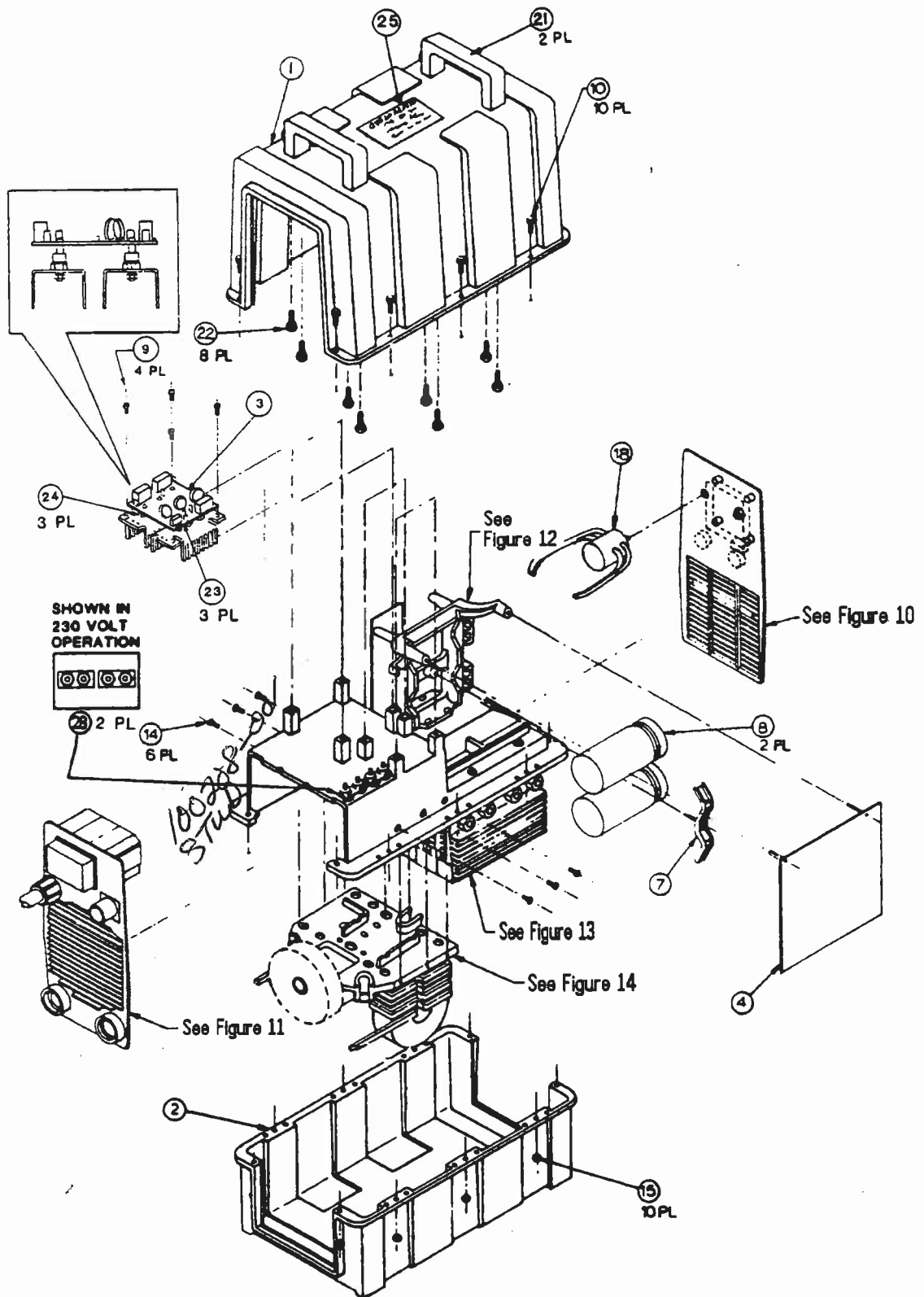

Figure 8, 230/460V Final Stick Assembly

# DRAWINGS & PARTS LIST

Parts List for Figure 9, Front Panel Assembly

Part No.	Qty	Part Name	Notes
2	1	101013-001	Front Panel, Silkscreen, SS
3	1	903000-002	Potentiometer 5K R100
4	1	<del>940000-002</del>	Knob 940024-001
8	1	941006-010	Pilot Light DS1
9	1	940001-001	Shaft Lock
10	1	941006-001	Speed Nut
11	1	920000-100	Knob Range Switch

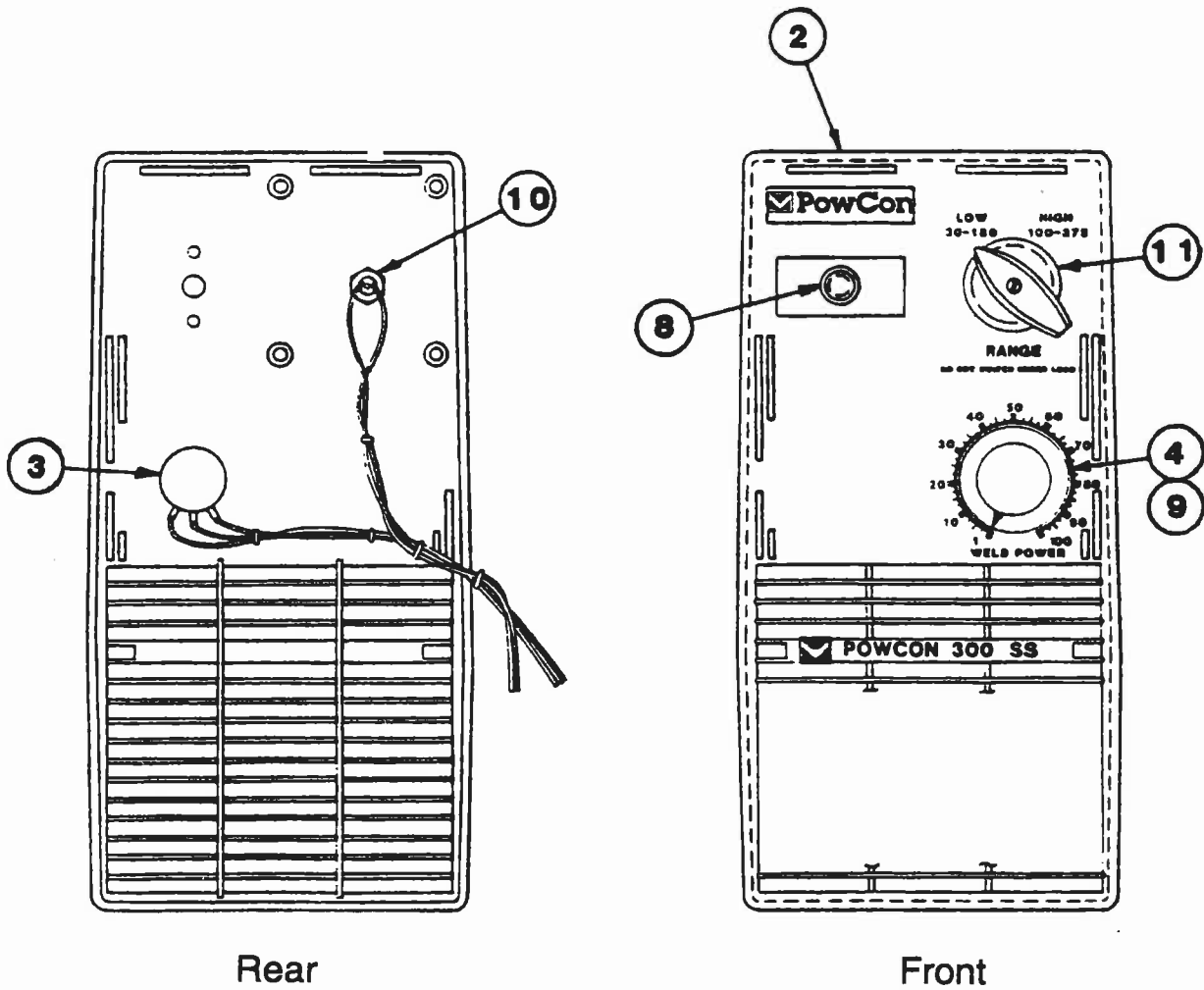

Figure 9, 230/460V Front Panel Assembly

# DRAWINGS & PARTS LIST

## Parts List for Figure 10, Rear Panel Assembly

2	1	100022-001	Rear Panel, Silkscreen	
3	4	970025-304	Screw, Supadrive, #6 X 3/8"	
4	1	930000-001	Connector, Remote, Female	J10
5	2	100025-001	Output Jacks, Tweco	J11, J12
Optional	2	100028-001	Output Jacks, Dinse	
6	3	250001-001	Hole Plug, Panel	
7	1	100005-001	Boot (moisture seal)	
8	1	100030-001	Bracket, Circuit Breaker	
9	1	940003-010	Locknut, 3/4" Conduit	
10	1	250002-001	Output Jack Assy Kit (with washers & brass nuts)	
12	4	970025-506	Screw, Supadrive, #10 - 32 X 1/2"	
13	1	921000-003	Circuit Breaker	CB1
14	1	250006-001	Input Cable Clamp	
16	1	930000-002	Sealing Cup	

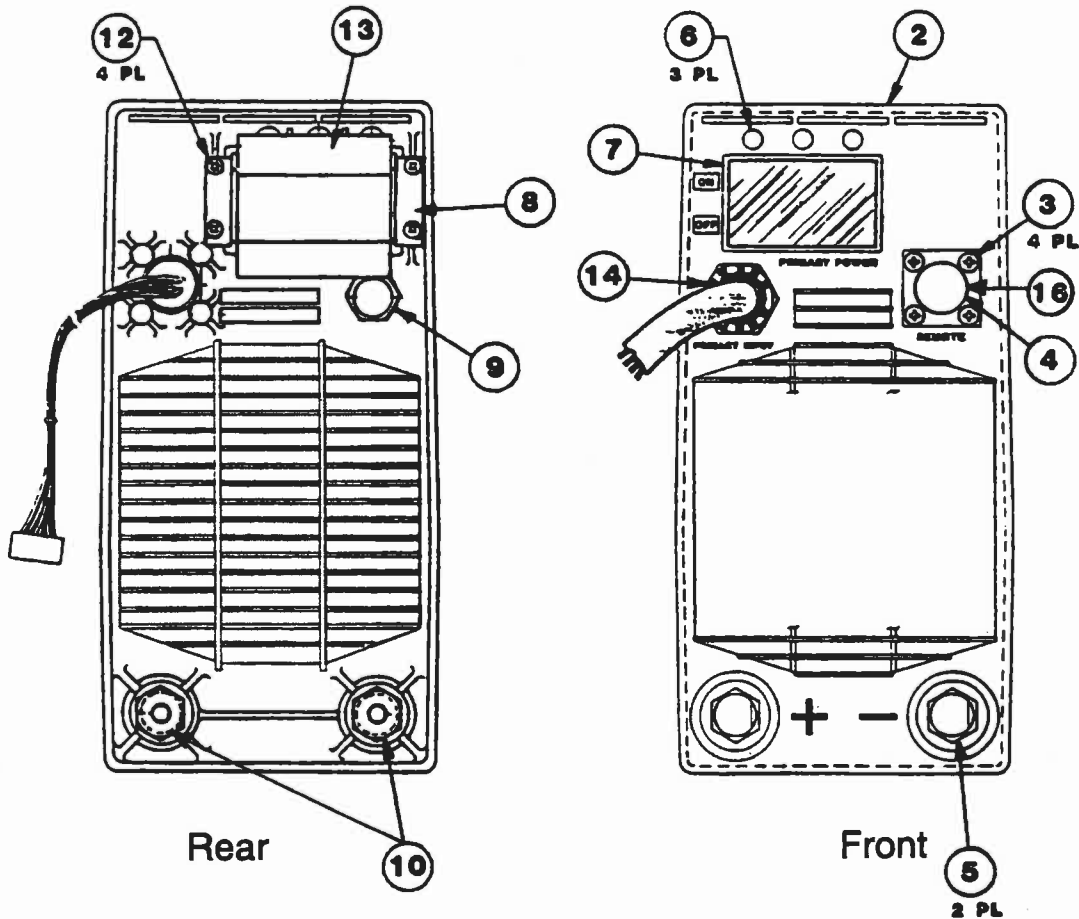

Figure 10, Rear Panel Assembly

# DRAWINGS & PARTS LIST

## Parts List for Figure 11, Capacitor Chassis Assembly

Item No.	Qty	Part No.	Description	Notes
1	1	100177-001	Capacitor Chassis	
2	1	100220-001	Assembly, PWB Cap Board	CR8, CR9, RV1, C 5 - 8
6	1	250004-001	Assy, Commutating Inductor Kit, rear (includes Items 12, 34)	L3
7	1	250005-001	Assy, Commutating Inductor Kit, front (includes Items 12, 34)	L2
8	1	902003-002	Power Resistor	R5
9	1	100128-001	Threaded Rod 10-32 X 5"	
10	1	100205-001	Washer, Locating Ryton	
11	9	972001-006	Nut, Flanged Hex, Self Locking	
12	2	970004-001	Screw, Case Bolt	
13	5	970002-506	Screw, PanHead, Self Locking, 10-32 X 1/2"	
14	2	100151-002	Buss Bar Voltage Change-over	
15	1	100232-001	Buss Bar - 4 holes	
16	2	100231-001	Buss Bar - 3 holes	
25	1	250003-001	Power Resistor Assembly, Kit (includes Items 9, 10, 11)	
30	1	912002-001	Diode (Anode to Stud)	CR8
31	1	912002-002	Diode (Cathode to Stud)	CR9
32	1	902011-003	Varistor	RV1
33	1	100237-001	Change-over Label	
34	2	974000-005	Washer	

# DRAWINGS & PARTS LIST

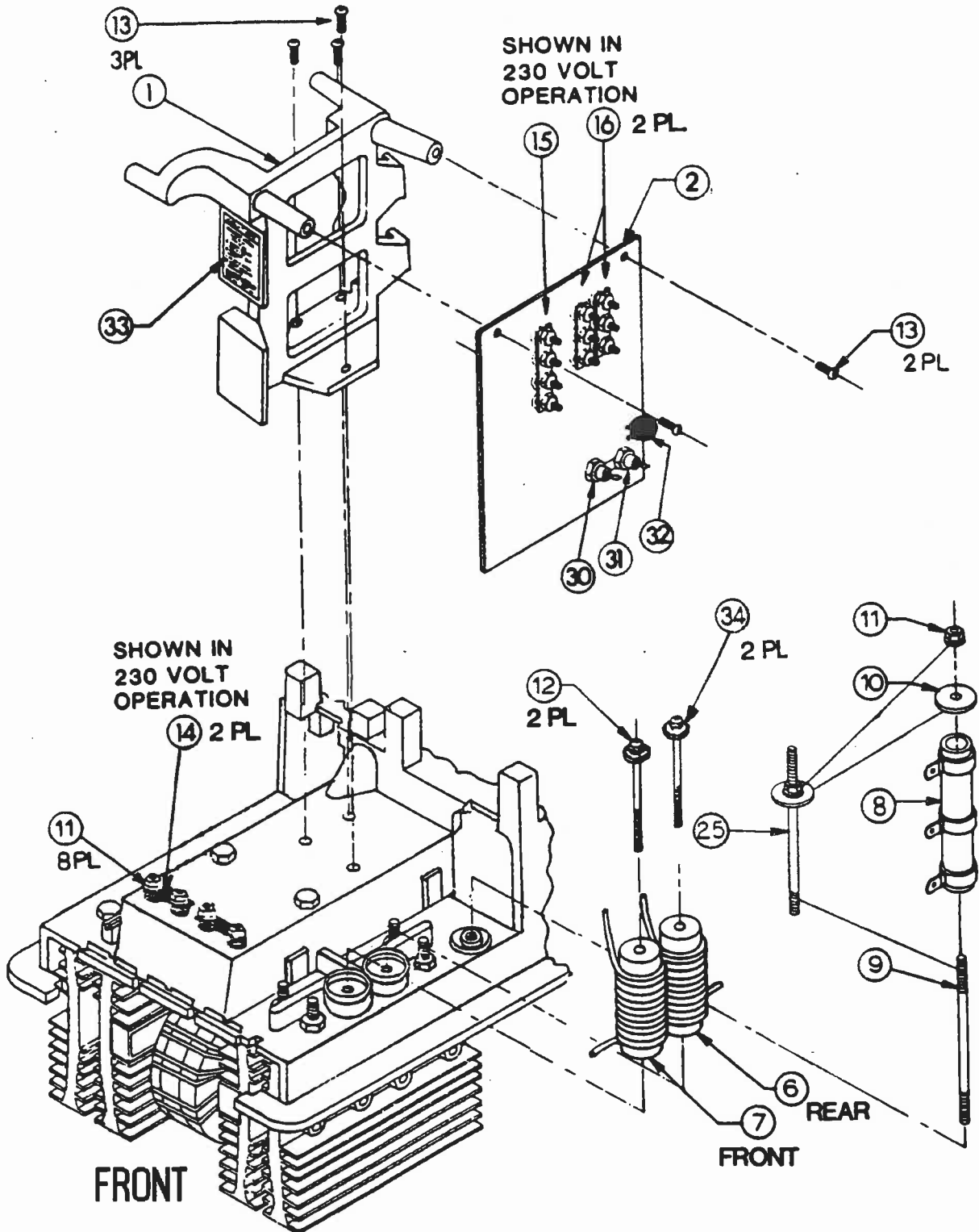
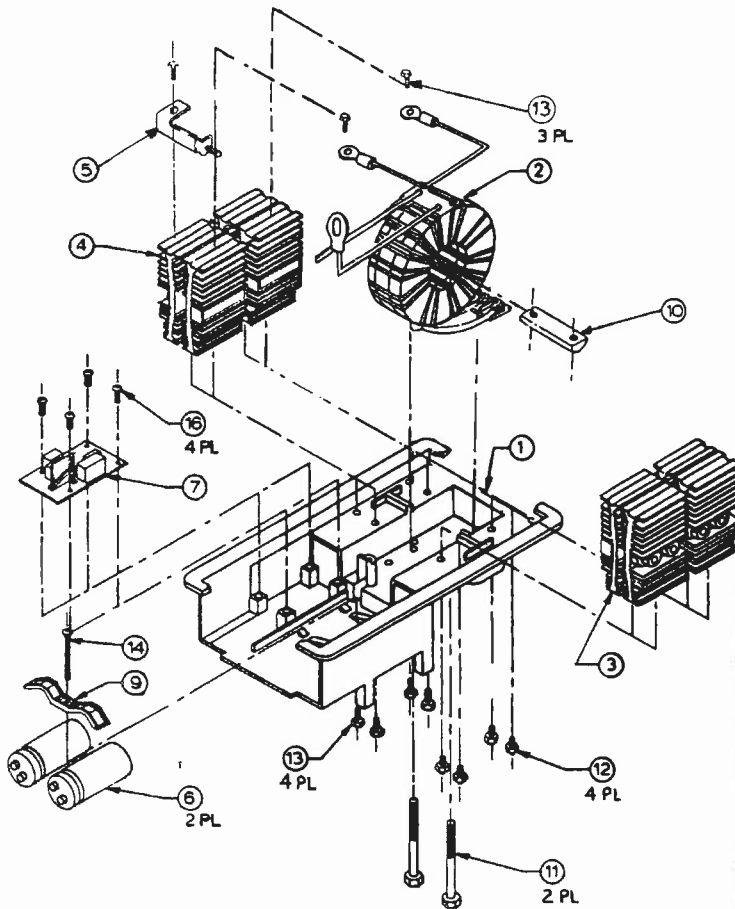

Figure 11, 230/460V Capacitor Chassis Assembly

# DRAWINGS & PARTS LIST

## Parts List for Figure 12, Chassis Plate Assembly

Part No.	Qty	Part Number	Description	Notes
1	1	100190-001	Chassis Plate	
2	1	100189-001	Assembly, Main Transformer	T2, RT1
3	1	100216-001	Assembly, SCR Heatsink	Q1 - Q2
4	1	100215-001	Assembly, WR Heatsink	CR11 - CR12
5	1	100057-001	Assembly, Shunt Resistor	SH1
6	2	900001-001	Output Capacitors	C13 - C14
7	1	100241-001	Assembly, PWB Output Board	R9,10,R6,R7,C11,C12,C15, C16
9	1	100167-001	Clamp, Capacitor	
10	1	100183-001	Bracket, X-former Mounting	
11	2	970006-628	Screw, Hex Head, 1/4-20 X 3 1/2"	
12	4	100117-001	Screw, Special Shoulder	
13	7	970006-606	Scr, Flanged, HexHead, 1/4-20 X 1/2"	
14	1	970002-518	Scr, PanHd, Posi-drive, 10-31 X 1 1/2"	



### Figure 12, 230/460V Chassis Plate Assembly





# DRAWINGS & PARTS LIST

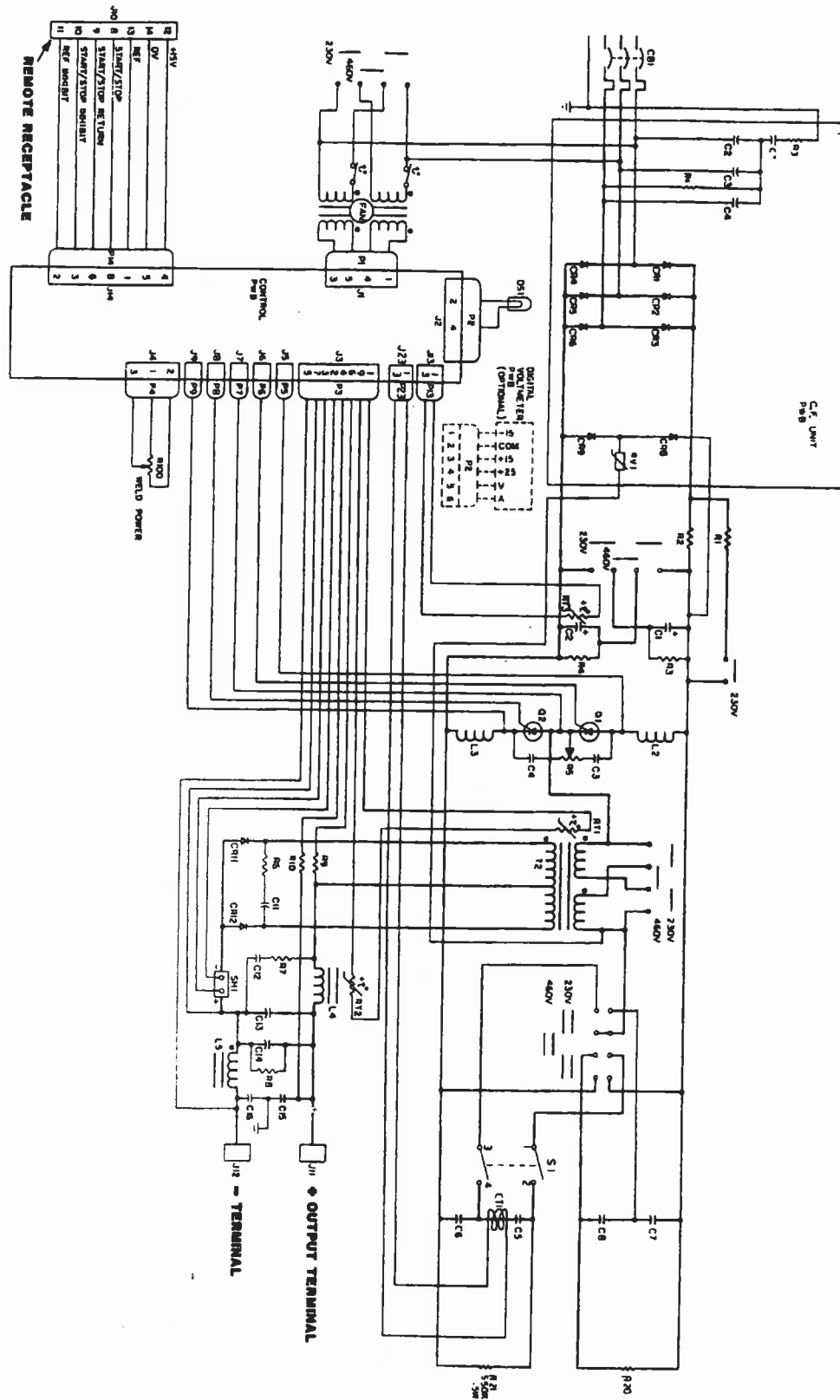

Figure 14, Schematic, PowCon 300SS 230/460V

 **PowCon<sup>®</sup>**  
*Shaping the Future*